

DRUM ROTATOR DC-R3-PBO SPECIFICATIONS

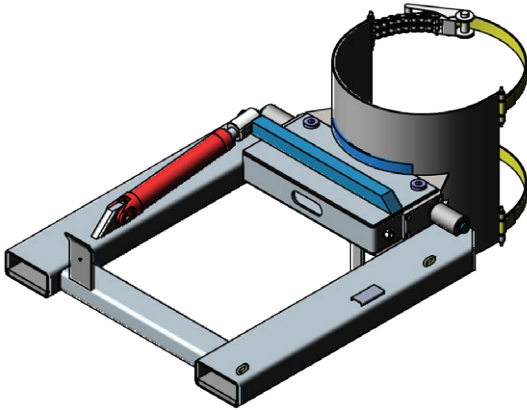

The DC-R3-PBO Hydraulic Drum Rotator is designed to safely lift and rotate a 205 litre plastic drum or barrel by forklift.

Features:

- Allows emptying of product from a 205L plastic drum or barrel by forklift
- Suits 205L plastic drums and barrels weighing up to 350kg
- Dual woven and chain belly strap with ratchet secures drum in position
- Rotation provided by forklift hydraulics and controlled by the auxillary function lever
- Slip-on attachment and quick connect hydraulic couplings allows quick connection to a forklift
- Commonly used in the food processing, recycling and mining industry
- Enamel paint finish

| | |
|--------------------------|------------|
| Working Load Limit (WLL) | 350kg |
| Load Centre | 1400mm |
| Rotation | 130° |
| Unit Weight | 184kg |
| Fork Pocket Size | 185 x 65mm |
| Fork Pocket Centres | 884mm |
| Horizontal C of G | 824mm |
| Vertical C of G | 5mm |

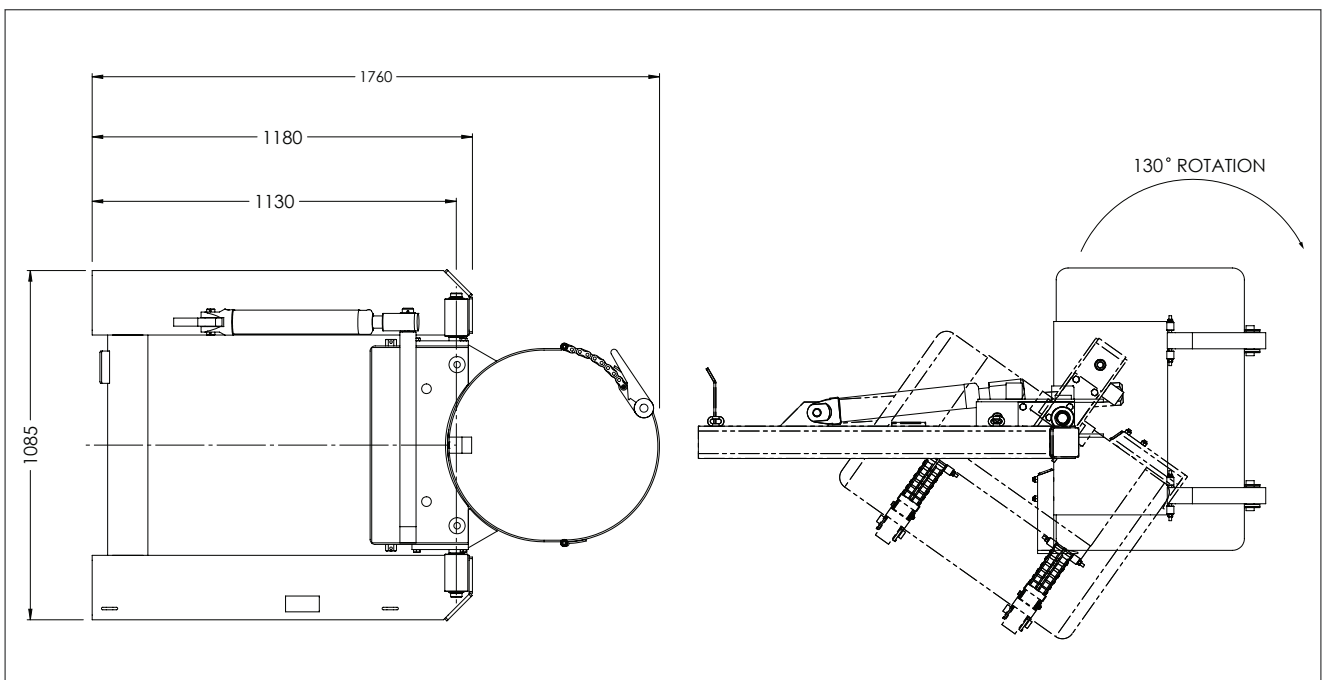

Australia Wide Sales & Service

sales@materialshandling.com.au | www.materialshandling.com.au | 1300 65 00 35

MATERIALS
Handling PTV LTD *Working with ease.*