

DRUM ROTATOR DC-R3 SPECIFICATIONS

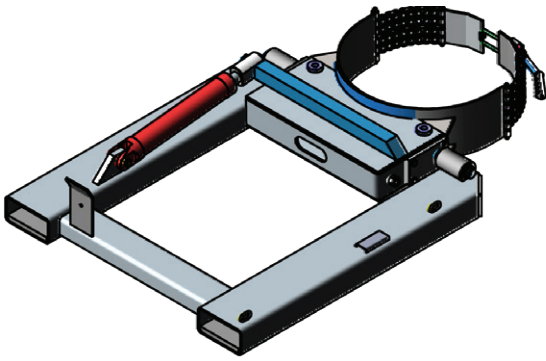

The DC-R3 Hydraulic Drum Rotator is a heavy-duty 205 litre drum lifter with hydraulic rotation ability, allowing the safe and reliable emptying of drums.

Features:

- Use with a forklift to lift and rotate a drum 130 degrees, allowing for emptying of product
- Heavy lift capacity suits 205L drums weighing up to 1000kg
- Belly strap and eccentric lock secures drum in position
- Rotation provided by forklift hydraulics and controlled by the auxillary function lever
- Slip-on attachment and quick connect hydraulic couplings allows quick connection to a forklift
- Commonly used in the food processing, recycling and mining industry
- Enamel paint finish

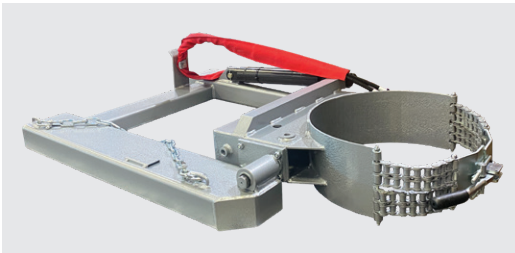

Working Load Limit (WLL)	1000kg
Load Centre	1400mm
Rotation	130°
Unit Weight	162kg
Fork Pocket Size	185 x 65mm
Fork Pocket Centres	884mm
Horizontal C of G	775mm
Vertical C of G	5mm

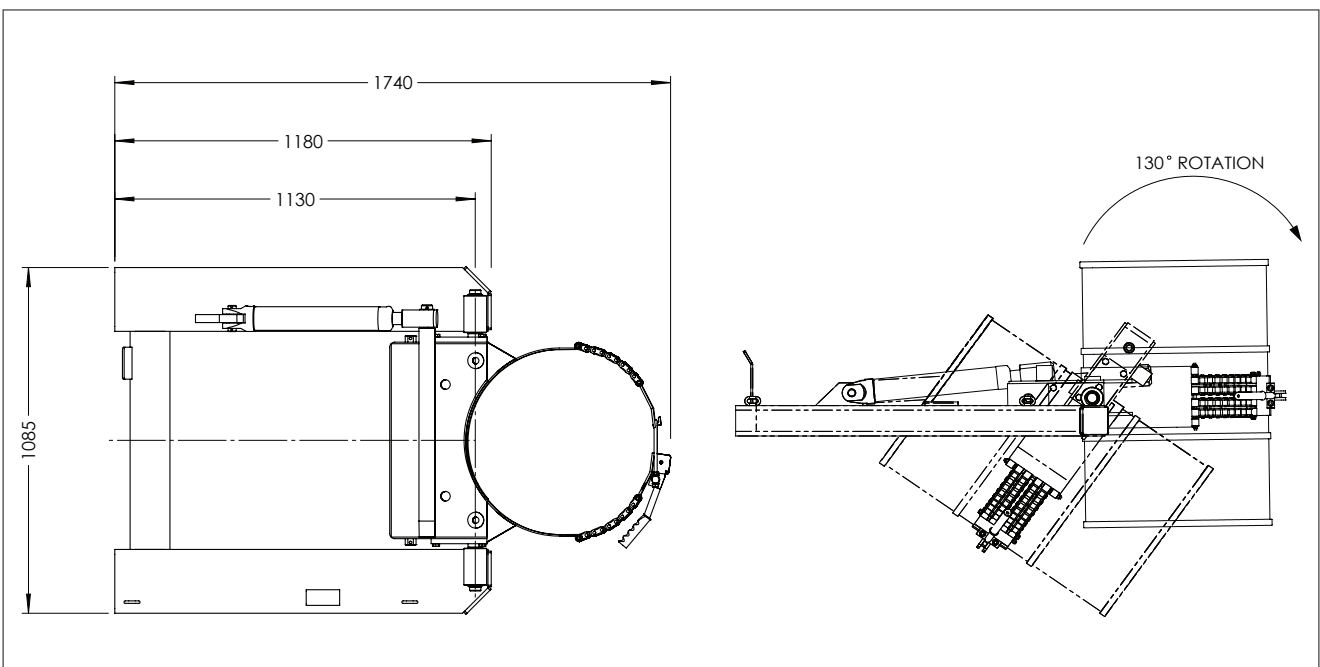

Australia Wide Sales & Service

sales@materialshandling.com.au | www.materialshandling.com.au | 1300 65 00 35

MATERIALS
Handling PTY LTD *Working with ease*