

LIFTING BEAM SPECIFICATIONS

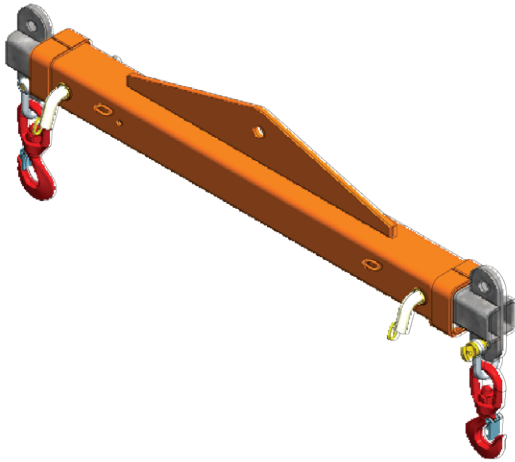

The LCEXL1218 Crane Spreader Beam is a multitasking beam designed to lift long loads by overhead crane.

Loads can be lifted via the centre single hook point (as a Lifting Beam), or end lifted using a 2 leg chain sling (as a Spreader Beam).

Features:

- Multi-tasking beam can be used as a Lifting Beam or Spreader Beam
- Load connection points are adjustable to 3 positions by moving the extendable arms
- Safety pins used to securely lock extendable arms in position
- Supplied standard with 2 safety swivel hooks
- Certified to the relevant Australian Standards
- Zinc finish on extendable arms, enamel paint finish on main body



Fully retracted



Fully extended

Working Load Limit (WLL)	See load chart below
Unit Weight	55kg

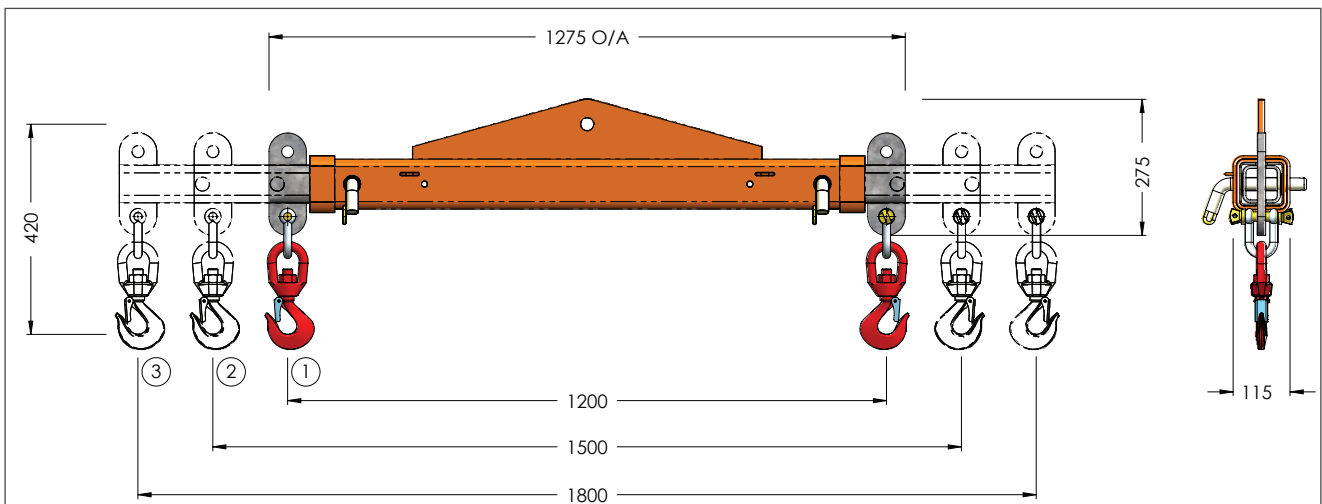

RATED CAPACITY (RC)

WHEN USED AS	FULLY RETRACTED (LC @ 1200mm)	MIDDLE POSITION (LC @ 1500mm)	FULLY EXTENDED (LC @ 1800mm)
LENGTH	1275mm	1575mm	1875mm
LIFTING BEAM	3000kg	2000kg	1000kg
SPREADER BEAM	5000kg	5000kg	5000kg

NOTE: Spreader beam working load limit has been calculated on a 60° chain angle setup.