

4-WHEELED CONTAINER SYSTEMS

1100 LITRE FLAT LID CONTAINER: THE BEST IN ITS CLASS



**UNIQUE DESIGN
EASY HANDLING
IMPROVED SAFETY**

Improved handling

- Easy grip handles on all sides
- Optimum manoeuvrability
- Compatible with identification and weighing systems



Increased safety

- Foot pedals on the front wheels lock the bin in position
- Increased stability
- Directional locks are ideal for use with towing equipment



Benefits

- Accessories easily fitted
- Complies to EN840 standard
- Safe and easy handling



1100 Litre Flat Lid Container

Material

- Polymer components:
 - Injection moulded from specially designed HDPE
 - Resistant to decay, frost, heat and chemicals
 - Special UV-stabilisers provide excellent ageing characteristics
- Corrosion resistant steel components
- Noise reduction:
 - Wheel assemblies with solid rubber tyres
- Long service life:
 - High quality materials
 - Excellent manufacturing processes
 - Withstands exposure to high mechanical stress levels
- Recycling:
 - All container parts are recyclable

Design

- Easy handling through the use of ergonomic handles
- Versatile, with a comprehensive accessories range
- In accordance with the safety requirements of EN-840
- Easy grip handles on all sides
- Safe, easy handling, even with heavy loads
- Various wheel assembly configurations for different applications
- Improved water drainage as a result of rounded lids
- Water drainage plug as standard*
- Compatible with identification and weighing systems
- Reinforced base, front and rear panels for greater stability
- Fitted as standard with chip nest in accordance with RAL GZ 951/1
- Easy to clean due to smooth surfaces and rounded internal corners

Accessories

- For accessories and special design variations such as lid apertures, locks and towing brackets, please refer to the separate accessories sheet for 4-wheeled containers

Quality

- Certified according to DIN EN 840 and RAL GZ 951/1
- Constant quality control through manufacturers laboratory as well as independent institutes

Dimensions - Weights - Standards

- Nominal volume: 1100 litres
- Net weight: approx. 65 kg
- Max. load: 440 kg
- Permitted total weight: 510 kg

Measurements to be used as a guide only - variations will occur

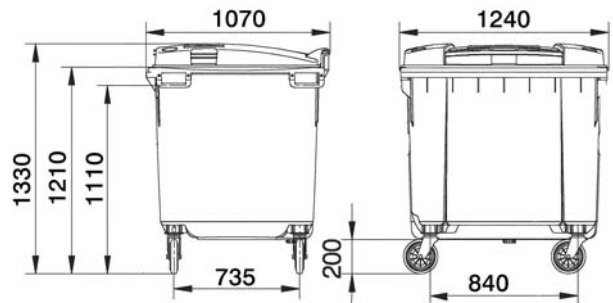

Colours

- Standard colours: green, blue, yellow
- Special colours are available on request*
- All additives are cadmium free and environmentally friendly



Imprints and markings

- Manufacturer, year of manufacture, material
- Nominal volume, max. permitted total weight
- EN 840, RAL markings
- Individual markings with imprints, hot-foil printing or adhesive labels available on request *