

## Technical data sheet

Type: 680000 Universal conveyor long: loading and unloading of tyres

Electrically operated conveyor with height adjustable platform

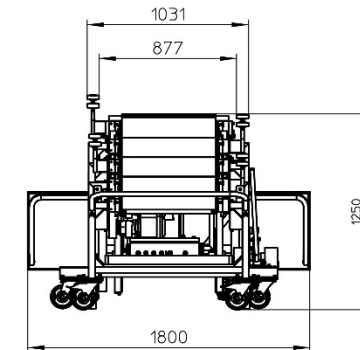
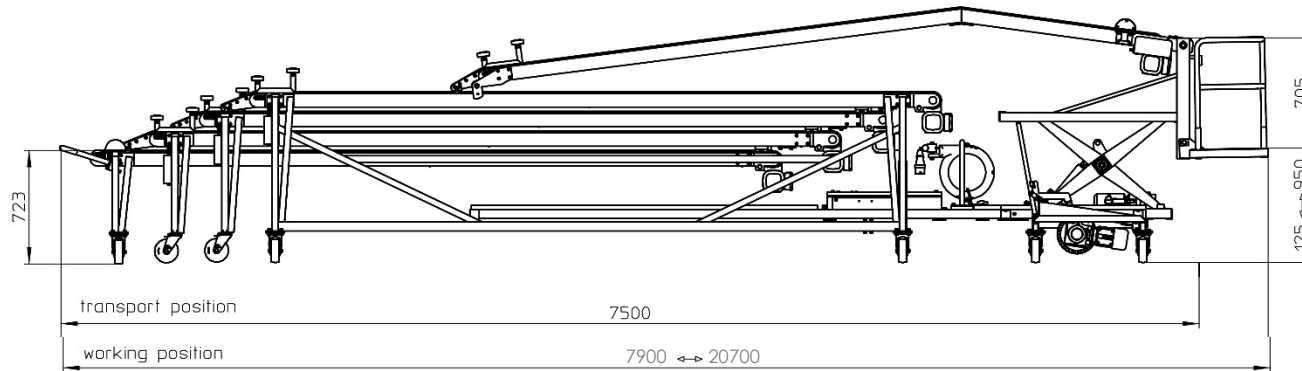

### Technical data

Adjustable lift height: 825mm  
Belt speed: variable from 0,3m/s - 0,7m/s  
Min. ambient temperature: -15°C  
Max. ambient temperature: 50°C  
Protection class: IP54

### Electrical data

Network voltage/ frequency: 380V ~ +/-5%, 50Hz +/-2%  
Power : Max. 2,0KW / rated power 1,6KW  
Wall device plug: CEE 400V, 16A, 5Pin (3L+N+PE)  
Motors: SEW 380V  
Belt: modular belt  
Hydraulic power unit: 380V

### Dimensions

Length transport position: 7500mm  
Length working position: 7900 - 20700mm  
Width working platform: 1800mm  
Conveyor belt width: 601mm  
Weight: approx. 980kg

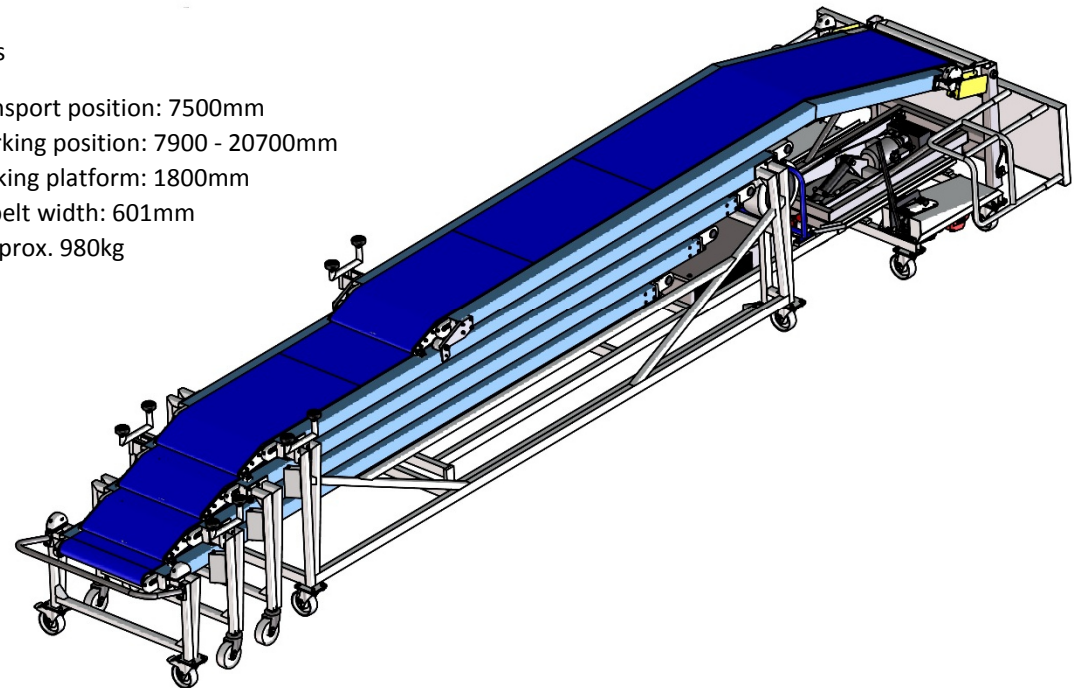

**MATERIALS**  
**Handling** *Working with ease...*  
PTY LTD

Our website: [www.materialshandling.com.au](http://www.materialshandling.com.au)  
Phone us: 1300 65 00 35 Fax us: 1800 68 68 96  
Email us: [sales@materialshandling.com.au](mailto:sales@materialshandling.com.au)

**Australia Wide Sales and Service**