

BATTERY ELECTRIC VEHICLE JACK L SPECIFICATIONS



12,0 km/h



500 kg



1.500 kg



- Can tow loads up to 1500 kg and load up to 500 kg.
- Wide load platform.
- Narrow steering radius.
- Pneumatic wheels for both indoor and outdoor use.
- 5-levels speed adjustment.
- Wide range of accessories and connections.

👁 Front View



👁 Side View

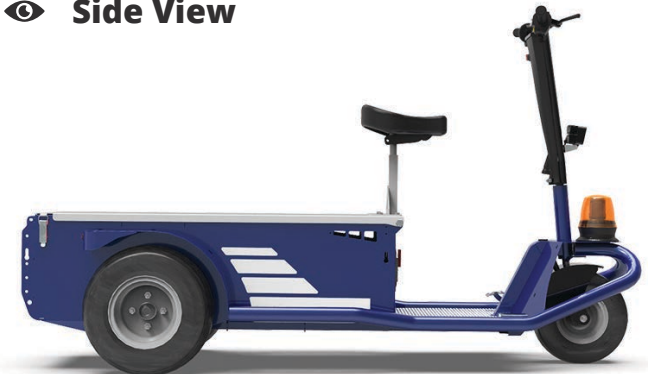

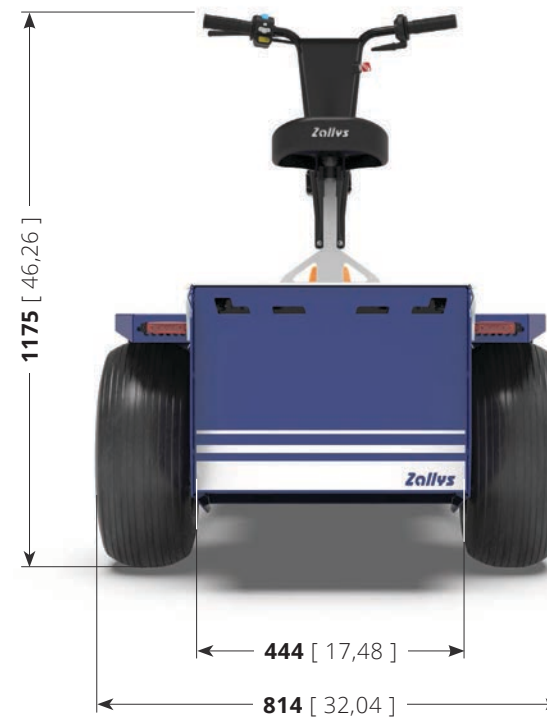
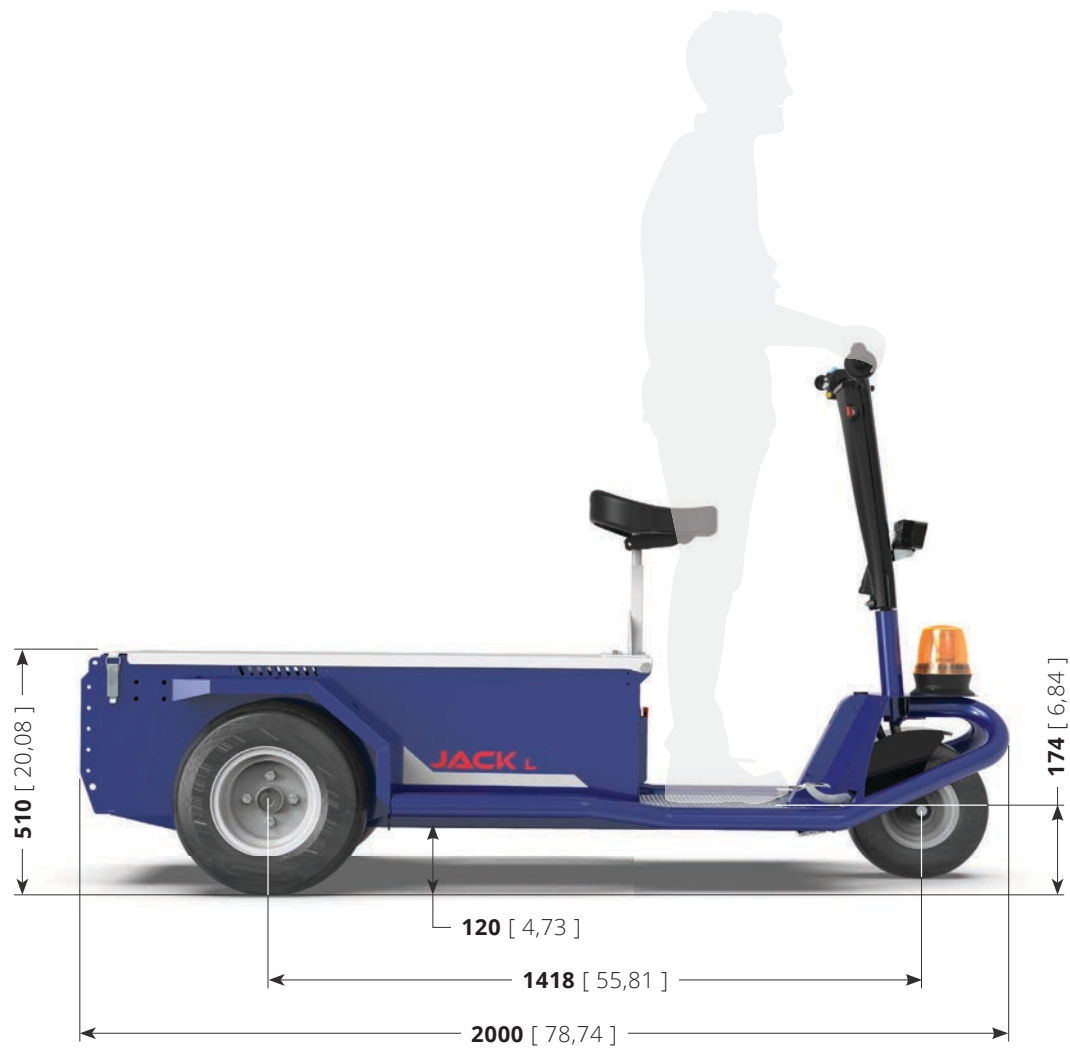

Zollys[®]

TABLE:

JACK L

Unit: mm [inch]

Main sectors



HOSPITALS



HOTELS, RESORTS
& TOURISM



GREEN
MAINTENANCE

Performances on slopes

While the force expressed in N at the hook remains unchanged, **the towing capacity expressed in kg and the load capacity may vary based on:**

- **type of ground** on which the towing is performed;
- towing on **flat ground or on a slope**;
- use (or not) of **ballasts**;
- **type of wheels** mounted on the vehicle and on the trailer.



= Standard Version



= With Upgrade

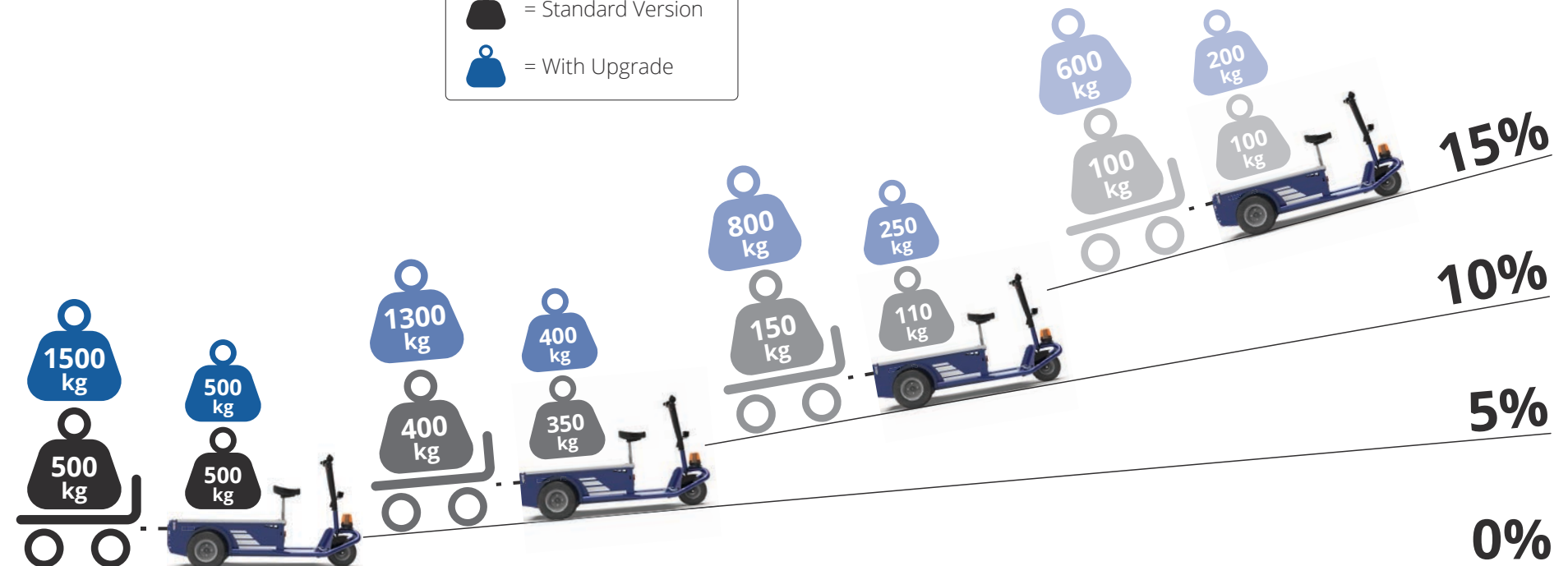

Ergonomic driving

JACK L's handlebar is studied to make the use of the machine more ergonomic and to guarantee great **comfort on a prolonged use** during the work shift. **All the driving controls are at your fingertips**, and on the LED display are always visible the battery charge level and the selected speed; the power key is on the right for an easy and fast ignition. **The structure** is made of **resistant materials** in case of accidental bumps.

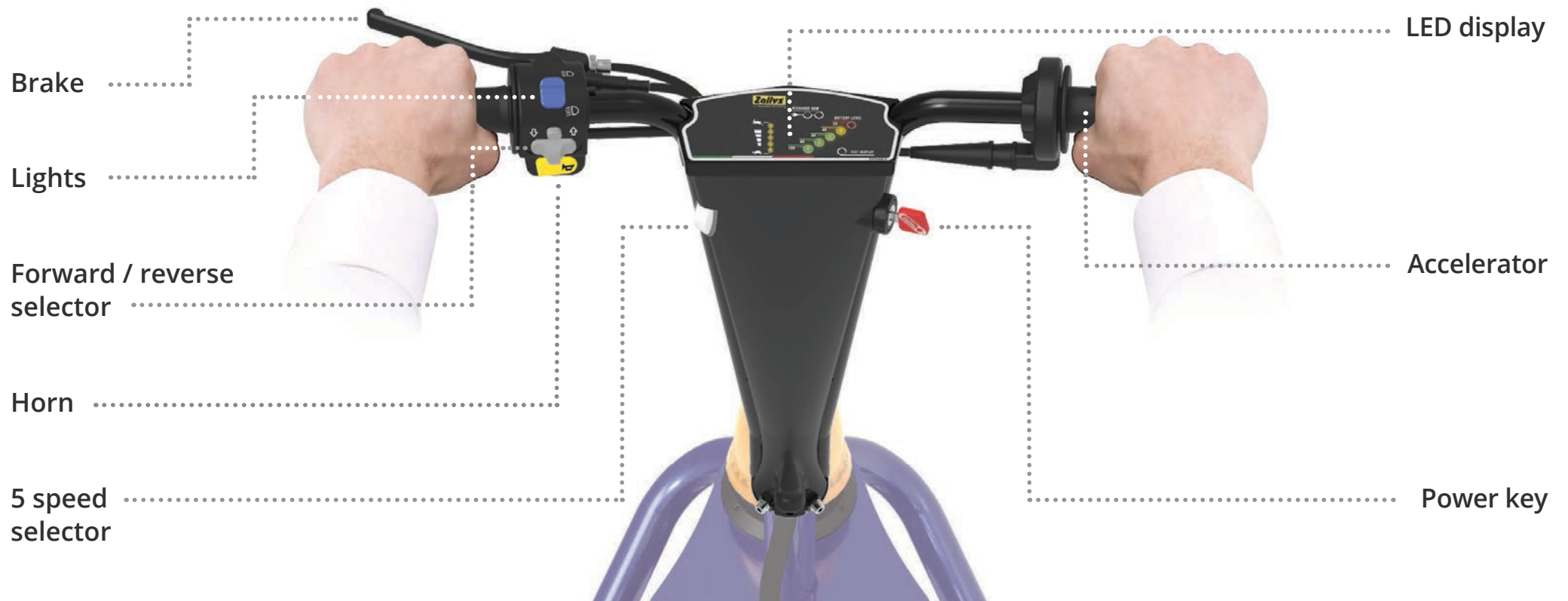

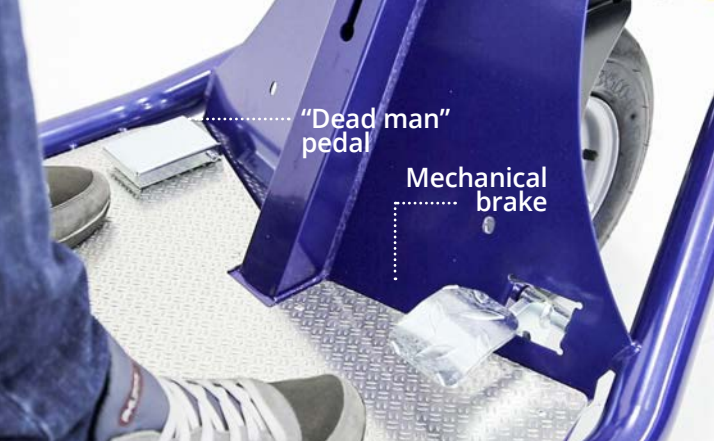

Maximum security

On JACK L's footboard there are two pedals, to guarantee the maximum security during the use:

- "dead-man" pedal: if not pressed, the driving controls are inactive, avoiding sudden and potentially dangerous movements when the machine is not in use;
- mechanical brake to stop the machine in case of emergency.



Autonomy for a full working day

JACK L is powered by two 105 / 130 Ah batteries, which guarantee the machine for **8 continuative working hours operation**. By purchasing the Upgrade, four 200 / 240 Ah batteries will be mounted in order to guarantee the same duration even with the improved performances. Thanks to the high frequency external battery charger, the batteries are easy to charge.



The right wheels for every need

JACK L mounts **pneumatic wheels** as standard, suitable for both indoor and outdoor use, and guarantee the maximum grip and a very low level of vibrations. Moreover, they are really resistant and offer exceptional performances on every terrain. On request it is possible to put on a different kind of wheels, such as **Tractor wheels** for irregular or uneven terrains, or the "**non-marking superelastic**" wheels, for delicate floorings.

STANDARD HITCH

JACK has a variety of accessories that can be equipped, to always configure the machine that meets the client's needs, such as **baskets** in various sizes for the transport of materials, several typologies of **hitches** for towing and accessories to increase security, such as **flashing beacons** and **protection carters**.



ACCESSORIES

Visibility in every work environment

JACK has **front and rear LED lights**, to drive even in those environments in which a correct lighting level is not always guaranteed, and a **flashing beacon** to indicate the position.



ACCESSORIES

Maximum agility for a more efficient use

JACK L's **footboard** is positioned at a minimum height from the ground, so stepping on and off the machine is quick and safe, **reducing operation time** and **increasing productivity**. On request, it is possible to equip a **comfortable backrest** in place of the seat in order to reduce the fatigue during longer journeys.

