

FORKLIFT CABLE DRUM LIFTER MDEX2 SPECIFICATIONS

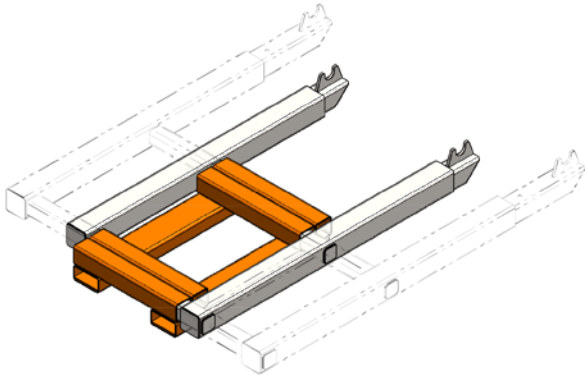

The MDEX2 Extensible Cable Drum Lifter is designed to safely lift and transport cable drums of various sizes by forklift.

Features:

- Ideal for heavy or large diameter cable spools
- Arms adjustable to 3 positions wide and 2 long to suit varying reel sizes
- Slip-on attachment and safety chain allows quick connection to a forklift
- Also available in a 1 tonne model (MDEX)
- Enamel paint finish frame, zinc finish telescopic arm



Working Load Limit (WLL)	2000kg
Load Centre (Retracted / Extended)	2120mm / 2470mm
Maximum Spindle Diameter	78mm
Maximum Reel Diameter	2500 mm
Inside Clearance	870-1830mm
Unit Weight	350kg
Fork Pocket Size	185 x 75mm
Fork Pocket Centres	610mm
Horizontal C of G	930mm
Vertical C of G	30mm

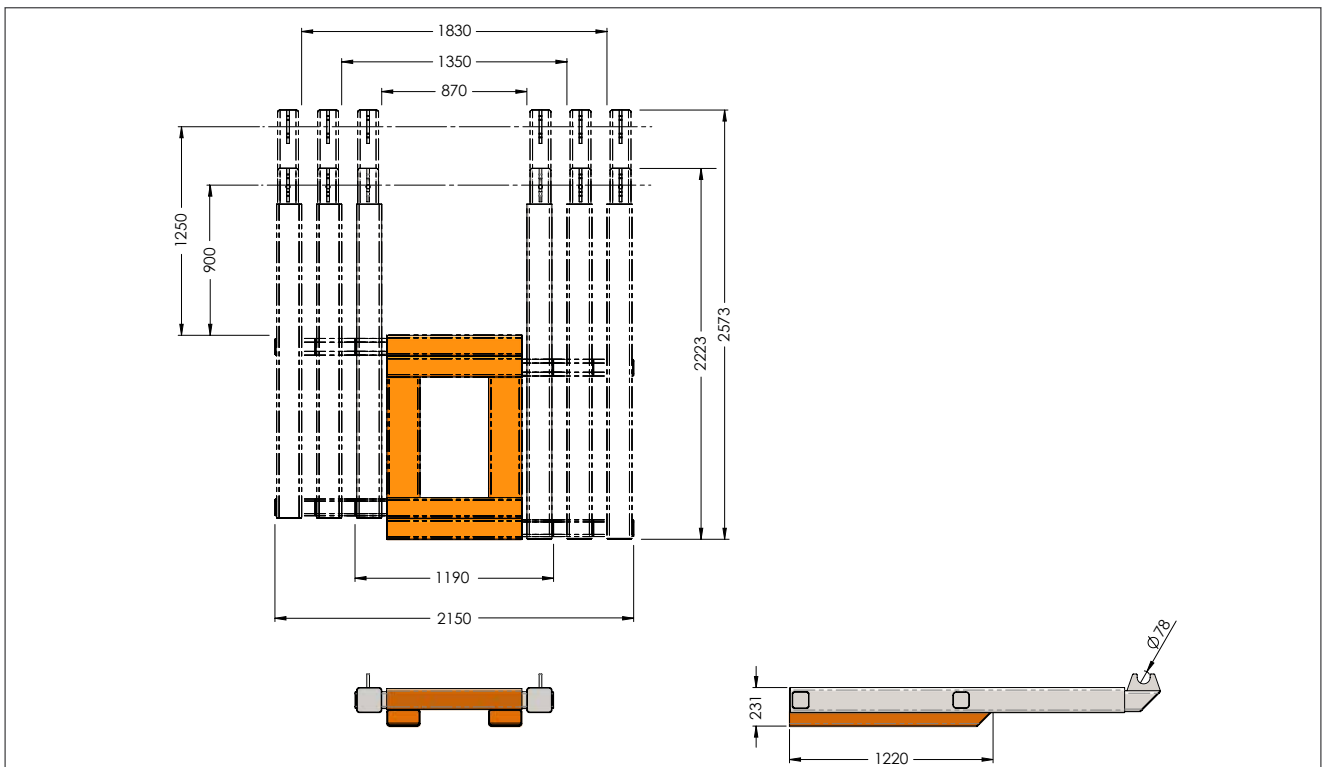

Australia Wide Sales & Service

sales@materialshandling.com.au | www.materialshandling.com.au | 1300 25 84 07

MATERIALS
Handling PTY LTD Working with ease.