

BULK BAG HOPPER MSKH100 SPECIFICATIONS

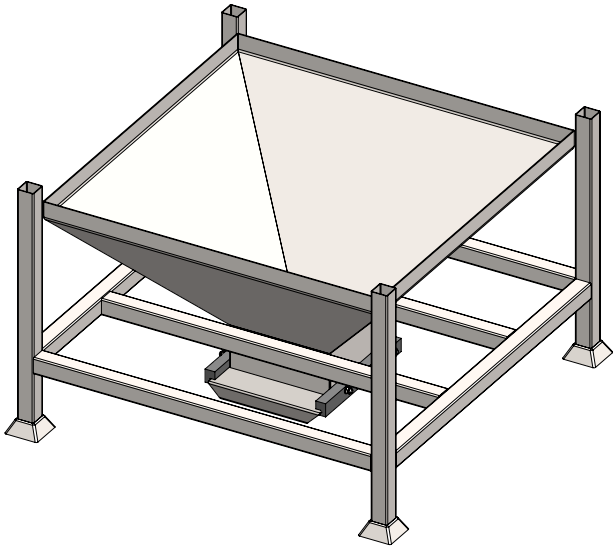

The MSKH100 Bulk Bag Hopper is designed for filling bulk bags with soil, sand, gravel, dirt and similar materials.

By using this item along with a MSKH100 Bulk Bag Frame, the bulk bag will be kept open under the Hopper's chute for a hands-free filling operation. The hopper chute is fitted with a stainless steel gate which slides in a Polyethylene rail. An optional Bag Piercing knife (MSKH-BP) can be ordered separately for ease of piercing source bags and discharging of materials into the hopper. The hopper is fitted with stacking feet to allow stacking 2 high in its standard configuration.

SPECIFICATIONS:

Working Load Limit (WLL): 1000kg

Unit Weight: 72kg

Volume: 0.25 cu.m

Finish: Zinc

