

# FORKLIFT TARP SPREADER MTS SPECIFICATIONS



The type MTS Tarp Spreader has been designed to safely cover high truck loads by Forklift. This slip-on attachment is easily fitted onto the fork tines and is secured by a safety chain.

The prong is secured by a locking pin and can be easily removed to allow convenient storage or if damaged.

The standard finish on the type MTS Tarp Spreader is enamel painted over primed steel.

## SPECIFICATIONS:

- Pocket size 185 x 65mm
- Pocket Centres 745mm
- Working Load Limit 200kg
- Load Centre 600mm
- Unit Weight 130kg
- HCG 500mm
- VCG 400mm

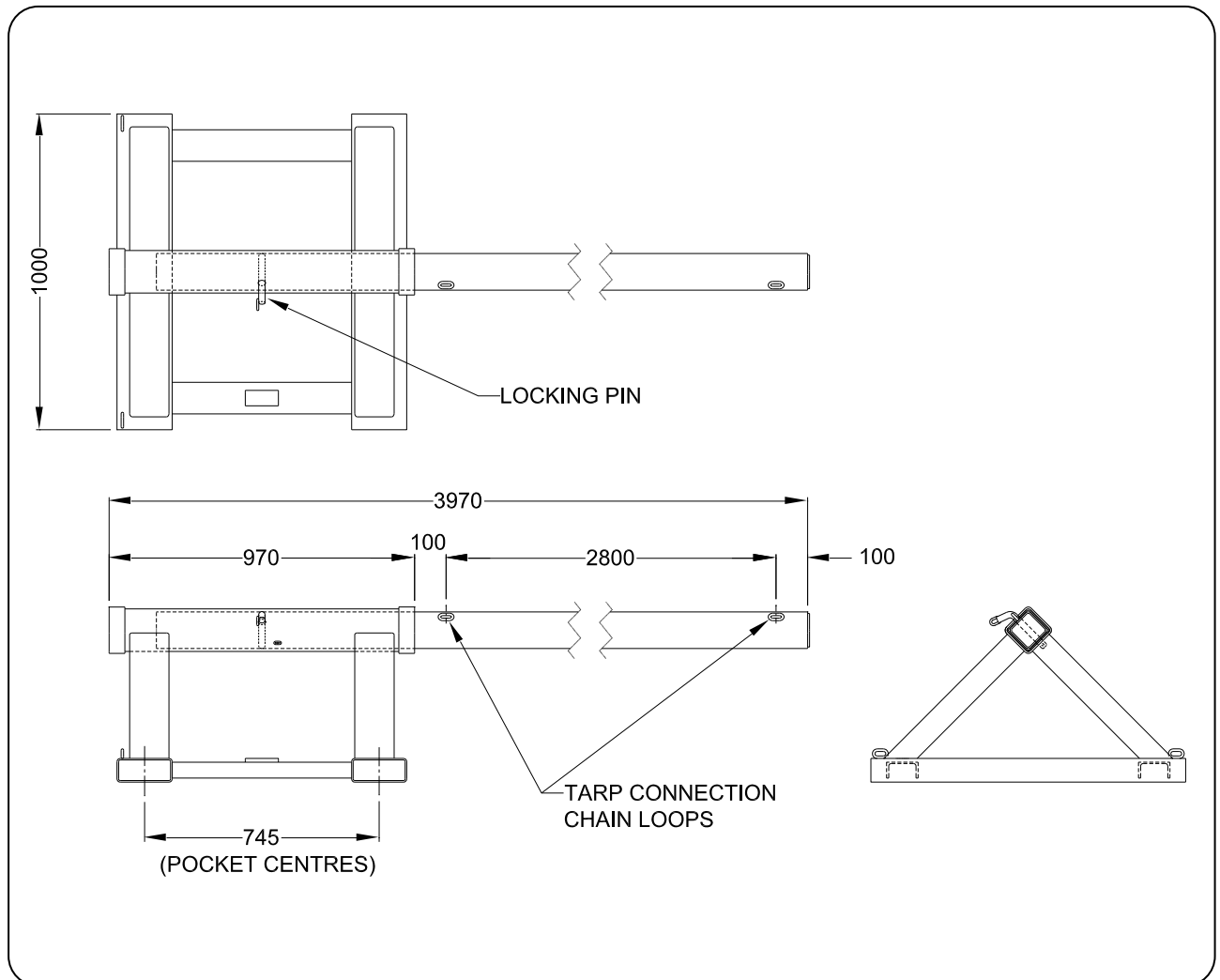

Australia Wide Sales & Service

sales@materialshandling.com.au | www.materialshandling.com.au | 1300 25 84 07

**MATERIALS**  
**Handling** PTY LTD Working with ease.