

# CONTROL HANDLE WITH ROUND BAR GRIPPER

The Rounded Bar end effectors meet the highest standard of ergonomics, working environment, safety and efficiency when integrated in Quick-Lift System.

They are easy to use, thanks to outstanding responsiveness, regardless of load weight. Built in energy save function.

Exceptional safety through built in warning function for insufficient vacuum, blow off and atmospheric pressure function.

High cost efficiency through high reliability and long durability. The Rounded bar end effectors provide strong solutions for quick and easy handling.

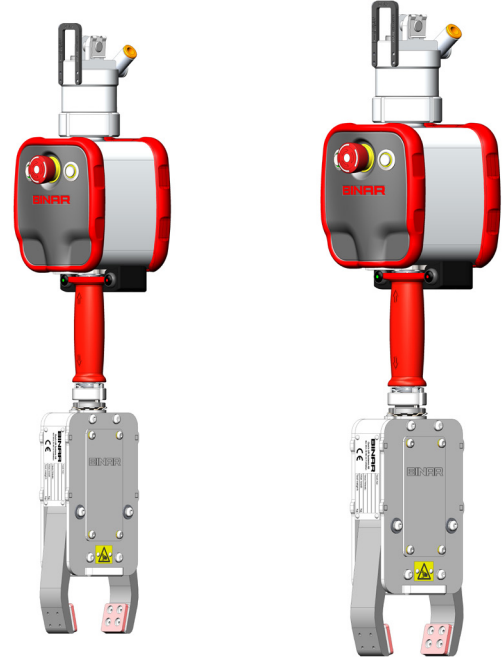
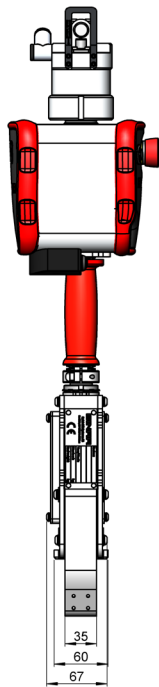
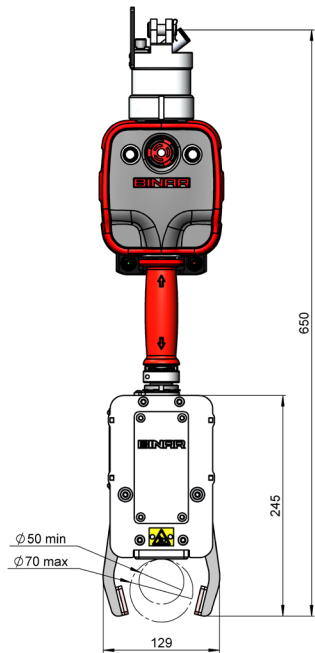

DESCRIPTION	PART.NO	WEIGHT KG
Round bar End effector pneumatic, max 30 kg	1015 204 010	10
Round bar End effector pneumatic, max 30 kg Rotated 90 deg.	1015 204 011	10
Round bars: Ø 50-70 mm, Length up to 1,5 m, Max weight 30 kg. Maximum lifting capacity is 30 kg when lifting in COG. The lifting capacity varies depending lifting object shape and gripping position.		
Round bar End effector pneumatic, max 45 kg	1015 205 010	10
Round bar End effector pneumatic, max 45 kg Rotated 90 deg.	1015 205 011	10
Round bars: Ø 70-90 mm, Length up to 1,5 m, Max weight 45 kg. Maximum lifting capacity is 45 kg when lifting in COG. The lifting capacity varies depending lifting object shape and gripping position.		

TECHNICAL DATA	
Temperature	For lifting objects 0-90°C
Air supply	Clean dry air, filtered, pressure 6,0 - 8,0 bar is required.
Safety	2x safety has to be applied on each lifting object. Safety function thanks to an integrated metal sensor that prevent lifting if not correct gripped - Stop-up.
Other	All Rounded bar end effectors are equipped with Control Handle, including mechanical swivel for integrated pneumatics and signal interface.

Binar Handling AB disclaims responsibility for any errors or incomplete information in the published material and reserves the right to make changes.

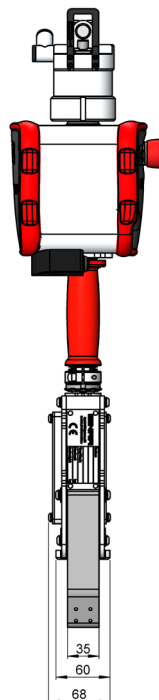
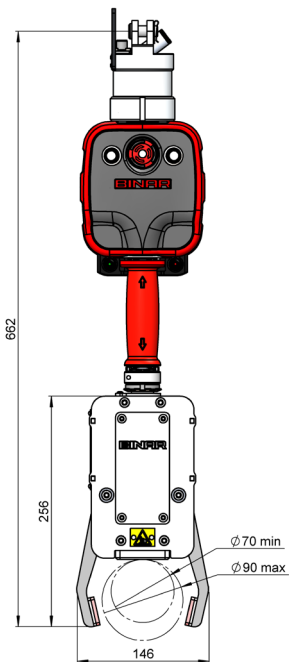

Australia Wide Sales & Service

sales@materialshandling.com.au | www.materialshandling.com.au | 1300 65 00 35

**MATERIALS**  
**Handling** *Working with ease*  
PTY LTD