



POWERED WHEELIE BIN TROLLEY

Smart solutions for
moving multiple wheelie bins.



WHEELIE BIN TRANSPORTER TRAILER



Powered Wheelie Bin Trolley

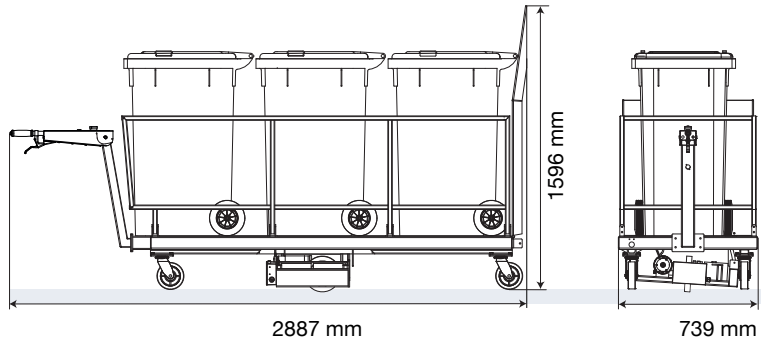

- Move up to three 240 litre wheelie bins, weighing up to 400 kg over a flat surface.
- Powered drive wheel can carry loads over ramps up to 5 degrees.
- Smart design with easy turning action.
- Tiller control keeps you in front of load.

Wheelie Bin Transporter Trailer

THREE-BAY BIN TRAILER

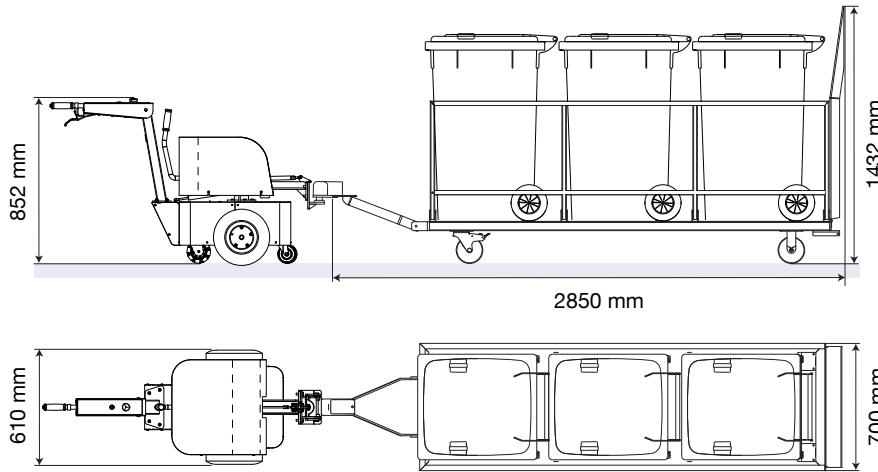

- Load capacity of up to 240 kg per bin bay.
- Compatible with 80, 120, 140, 240 and 360 litre wheelie bins.
- Gas strut actuated bin retention bar.
- Fits within one standard car parking space.
- Comes with a drawbar to suit pin hitch as standard.

SIX-BAY BIN TRAILER

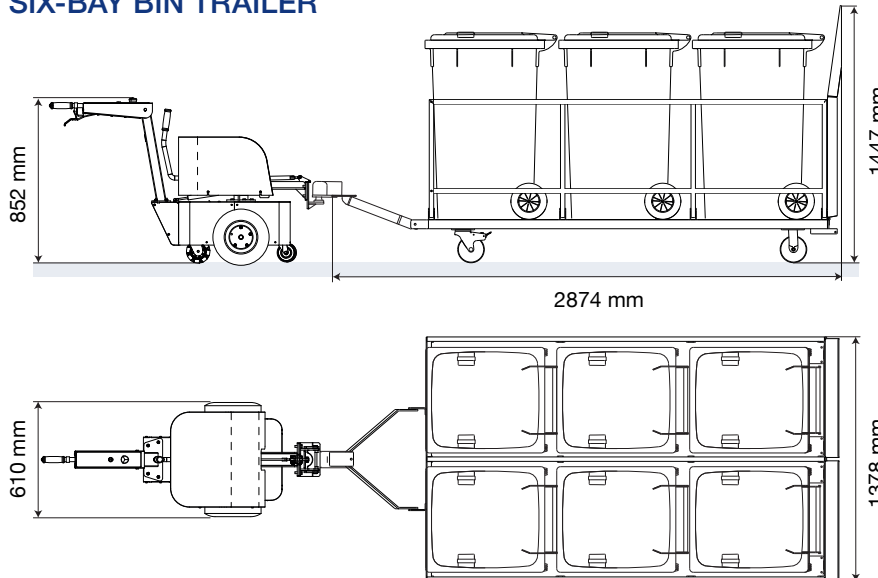

Safe

Move bins safely by maximising forward vision, reducing the risk of collisions and back and side strains.

Simple

No licence required and easy to use.

Strong

A single operator can safely move heavy loads.

Quiet

Smooth operation with zero emissions and low maintenance.

Local

Manufactured in Australia.

Australia Wide Sales & Service

sales@materialshandling.com.au | www.materialshandling.com.au | 1300 25 84 07

MATERIALS
Handling PTY LTD *Working with ease.*