

CARGO SHIELD SPILL BIN DSL4 SPECIFICATIONS

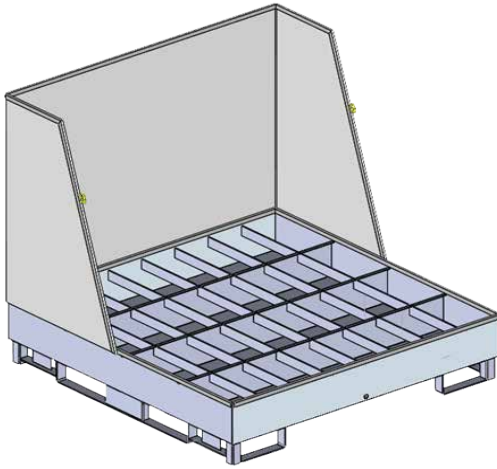

The DSL4 Cargo Shield Spill Bin provides complete protection against costly and environmentally damaging chemical spills from leaking drums. The baffled containment area allows the spill bin to be safely moved when full, minimising spillage.

FEATURES:

- Suits storage of up to 4 standard 205 L steel drums
- Cargo shield and safety chain fitted for added protection
- Close spacing support bars allows direct placement of large or small drums up to 2000 kg WLL
- Drain plug fitted at front of spill bin to allow emptying of containment area
- Elevated base allows transport by forklift or pallet trolley
- Steel fabricated, non-flammable unit
- Provides a spill capacity exceeding Australian Standards for 'portable' units
- Zinc finish

SPECIFICATIONS:

Working Load Limit (WLL)	2000 kg
Spill Capacity	245 L
Unit Weight	120 kg
Pocket Size	245 x 80 mm / 180 x 80 mm
Pocket Centres	450 mm / 910 mm

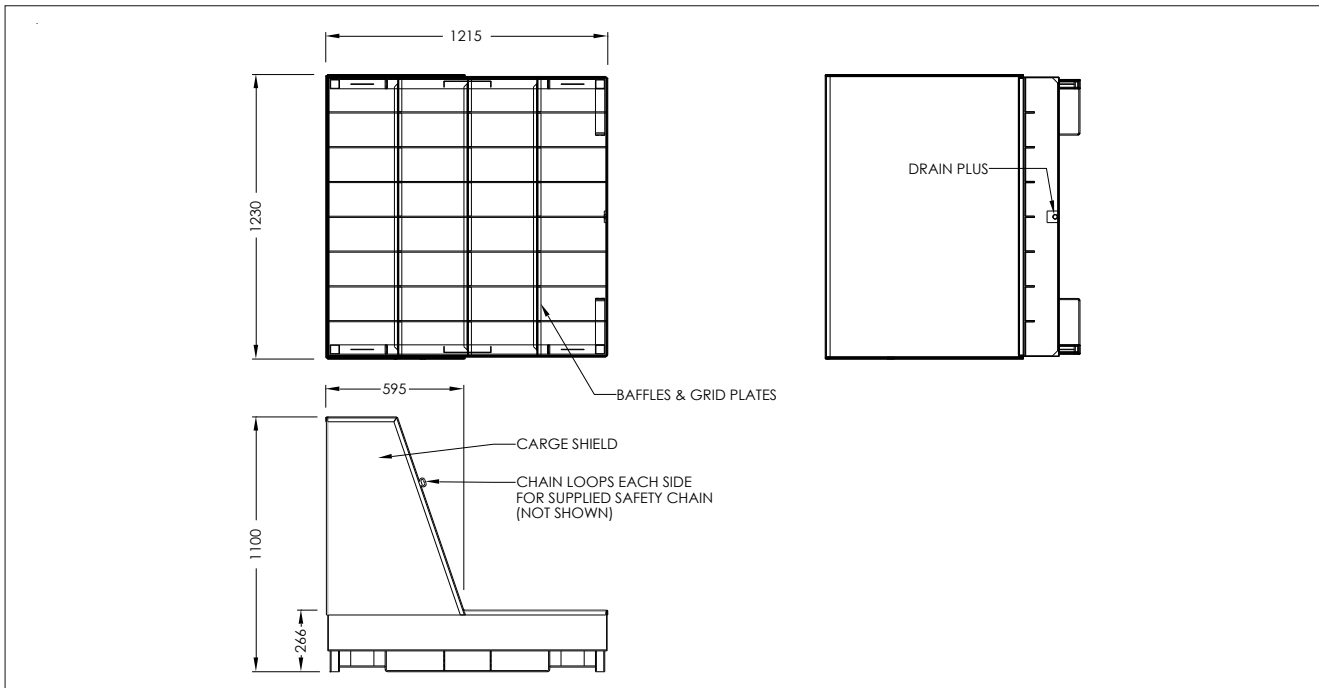

NOTE: Reference should be made to AS1940 and other relevant Australian Standards in regards to the maximum capacity allowed for the storage of flammable, dangerous or combustible liquids and necessary precautions required along with minimum separation distances. This unit exceeds the minimum spill capacity requirements of a portable bunding unit used for transit storage as per standard AS1940 (Flammable & Combustible Liquids), AS3780 (Corrosive Substances) and AS/NZS 3833 (Dangerous Goods).

Australia Wide Sales & Service

sales@materialshandling.com.au | www.materialshandling.com.au | 1300 25 84 07

MATERIALS
Handling PTY LTD *Working with ease.*