

LOAD TRANSFER STATIONS

LT35 SPECIFICATIONS

Load Transfer Stations are capable of transferring products that are packaged in cases, barrels, drums, bags and pails from one pallet to another including Plastic, Chep and GMA pallets in both receiving and shipping applications. Make your next load transfer an easy one with the LT35 model.

The Pallet-to-Pallet Load Transfer Station (LT35) is ideal for transferring from wood to plastic or aluminum pallets. The forklift driver activates the LT35 by using the overhead pull cord allowing the operator to cycle the machine from the forklift. The total transfer cycle is complete in less than 60 seconds.

Since the LT35 hydraulic and electrical components are self-contained, it can be positioned anywhere that can be reached with a 230 or 460-volt power supply. The LT35 can be loaded from either side and unloaded from three sides, allowing for the use of four-way pallets. The LT35 accepts 48" x 40" pallets and can be fitted with drop-in deck shims to accommodate different pallet heights. The automatic pallet stacker (magazine) will accept up to 20 standard pallets.

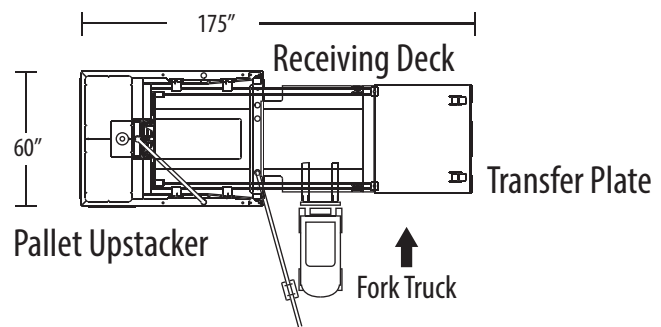

BENEFITS

- Eliminate injury to warehouse personnel
- Streamline plant and warehouse operations
- Less wear and tear of lift trucks
- Improve plant process cleanliness
- Reduce shipping costs
- Easy-to-operate (ETO)

Australia Wide Sales & Service

sales@materialshandling.com.au | www.materialshandling.com.au | 1300 25 84 07

MATERIALS
Handling PTY LTD Working with ease.

FEATURES

- Automatic pallet upstack holds up to 20 pallets
- Hydraulically actuated
- Heavy-duty construction
- Easy to operate
- 5 HP integral hydraulic power unit
- Weighs 2900 kg
- 1580 kg load capacity
- 3 Emergency stops
- Low maintenance
- Allen Bradley PLC controls
- 230, 460 or 575 VAC power supply
- 24 VDC controls
- UL / CSA rated control panel
- Machine mounted guarding
- Overhead pivot pole cord switch

OPTIONS

- Cold Climate Package: heaters for oil tank and control panel
- Receiving deck shim kit
- Pallet cart shim kit
- Stainless steel paint for wash down applications
- 3-way handling of outbound loads



Australia Wide Sales & Service

sales@materialshandling.com.au | www.materialshandling.com.au | 1300 25 84 07

MATERIALS
Handling PTY LTD Working with ease™