

LOAD TRANSFER STATIONS LTS SPECIFICATIONS

Load Transfer Stations are capable of transferring products that are packaged in cases, barrels, drums, bags and pails from one pallet to another including Plastic, Chep and GMA pallets in both receiving and shipping applications. Make your next load transfer an easy one with the LTS model.

The Load Transfer Station (LTS) is made up of a frame, receiving deck and a transfer plate. Since the LTS hydraulic and electrical components are self-contained, it can be accessed from two sides for loading or three sides for unloading. The integral pallet upstacker will accept up to 20 standard pallets. The actual cycle time of the machine is less than 60 seconds.

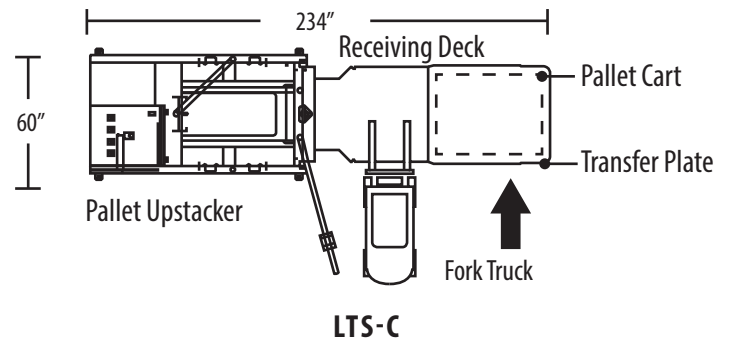
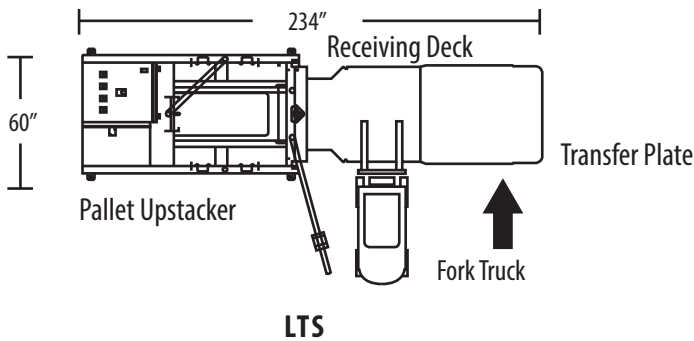

BENEFITS

- Eliminate injury to warehouse personnel
- Streamline plant and warehouse operations
- Less wear and tear of lift trucks
- Improve plant process cleanliness
- Reduce shipping costs
- Easy-to-operate (ETO)

Australia Wide Sales & Service

sales@materialshandling.com.au | www.materialshandling.com.au | 1300 25 84 07

MATERIALS
Handling *Working with ease.*
PTY LTD

FEATURES

- Automatic pallet upstack holds up to 20 pallets
- Hydraulically actuated
- Heavy-duty construction
- Easy to operate
- 5 HP integral hydraulic power unit
- Weighs 2900 kg
- 1800 kg load capacity
- 3 Emergency stops
- Low maintenance
- Allen Bradley PLC controls
- 230, 460 or 575 VAC power supply
- 24 VDC controls
- UL / CSA rated control panel
- Machine mounted guarding
- Overhead pivot pole cord switch

OPTIONS

- Cold Climate Package: heaters for oil tank and control panel
- Automatic pallet height adjustment
- Receiving deck shim kit
- Pallet cart
- Pallet cart shim kit
- Stainless steel paint for wash down applications
- 3-way handling of outbound loads
- Automatic load placement adjustment: inset, flush, overhang



Australia Wide Sales & Service

sales@materialshandling.com.au | www.materialshandling.com.au | 1300 25 84 07

MATERIALS
Handling PTY LTD Working with ease™