

# LOAD TRANSFER STATIONS LTSPDOC SPECIFICATIONS

Load Transfer Stations are capable of transferring products that are packaged in cases, barrels, drums, bags and pails from one pallet to another including Plastic, Chep and GMA pallets in both receiving and shipping applications. Make your next load transfer an easy one with the LTSPDOC model with Pallet Dispenser and Outfeed Cart.

The Load Transfer Station with Pallet Dispenser and Output Conveyor (LTSPDOC) includes the LTS, 3 chain pallet cart and pallet dispenser outfeed cart. The LTSPDOC operates in the same manner as the LTSPD with the addition of automatically "discharging" the transferred load away from the machine.

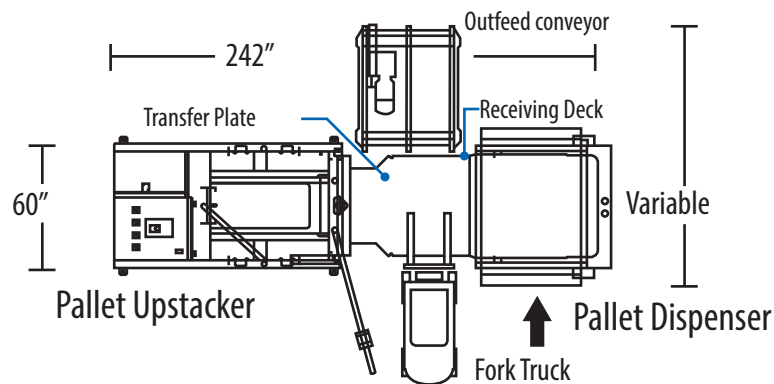

## BENEFITS

- Eliminate injury to warehouse personnel
- Streamline plant and warehouse operations
- Less wear and tear of lift trucks
- Improve plant process cleanliness
- Reduce shipping costs
- Easy-to-operate (ETO)

Australia Wide Sales & Service

sales@materialshandling.com.au | www.materialshandling.com.au | 1300 25 84 07

**MATERIALS**  
**Handling** *Working with ease.*  
PTY LTD

## FEATURES

- Automatic pallet upstack holds up to 20 pallets
- Hydraulically actuated
- Heavy-duty construction
- Easy to operate
- 5 HP integral hydraulic power unit
- 3-strand chain powered outfeed cart
- Category 3 safety features including light curtains
- Weighs 4535 kg
- 1600 kg load capacity
- 5 Emergency stops
- Low maintenance
- Allen Bradley PLC controls
- 230, 460 or 575 VAC power supply
- 24 VDC controls
- UL / CSA rated control panel
- Machine mounted guarding
- Overhead pivot pole cord switch
- Automatically dispenses "go to" pallet
- Panelview Plus touchscreen HMI

## OPTIONS

- Cold Climate Package: heaters for oil tank and control panel
- Automatic pallet height adjustment
- Receiving deck shim kit
- Slip sheet dispenser
- Stainless steel paint for wash down applications
- Automatic load placement adjustment: inset, flush, overhang



Australia Wide Sales & Service

sales@materialshandling.com.au | www.materialshandling.com.au | 1300 25 84 07

**MATERIALS**  
**Handling** PTY LTD Working with ease™