

# FORKLIFT MOUNTED MANUAL DRUM DUMPER DDR50 SPECIFICATIONS

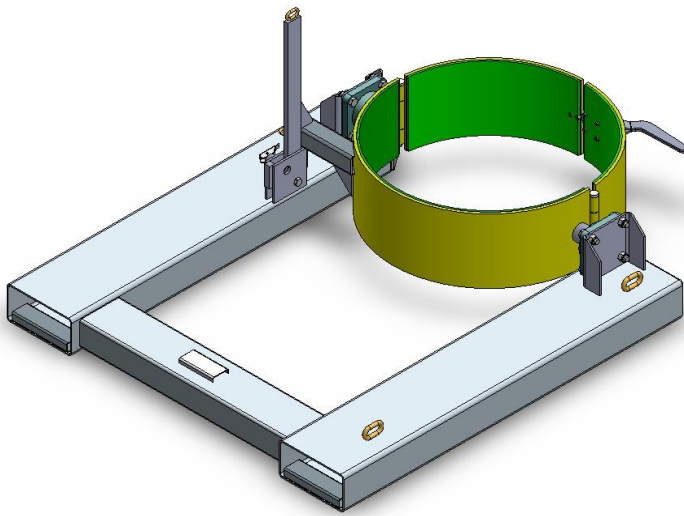

The type DDR50 Forklift Mounted Manual Drum Dumper is designed for fast and economical 205 litre drum emptying. A Belly Strap with an eccentric lock holds the drum firmly in position. To release the drum, the Operator pulls the draw chord from the driver's seat. With the drum C of G forward of the pivot point, the drum tips forward 180° plus automatically.

This unit is ideal for scrap and waste products. The standard finish of this unit is Zinc Plated.

## SPECIFICATIONS:

- Working Load Limit (WLL) 500 kg
- Unit Weight 85 kg
- 180-degrees plus Rotation
- Load Centre 950 mm
- Pocket Size 185 x 60 mm
- Pocket Centres 840 mm
- Horizontal C of G 685 mm

