

# GAS CYLINDER STORAGE RACKS

## GBSR8 SPECIFICATIONS

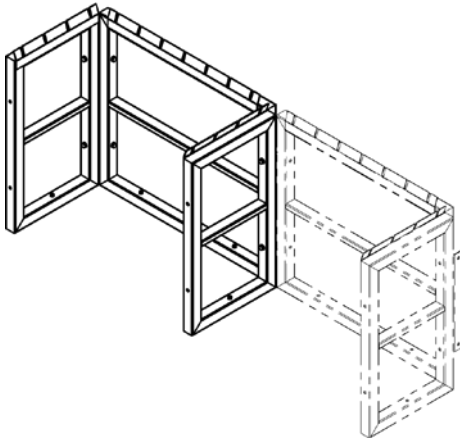

The GBSR8 Gas Cylinder Storage Rack is an effective indoor/outdoor bulk cylinder storage racking system designed for safety and flexibility. This modular unit allows growth in the number of cylinders stored at a site and the ability to organise and segregate gas cylinders by type, empty or full as per safety standard AS4332.

### Features:

- Safely secures and restrains gas cylinders indoors or outdoors
- Allows organisation and segregation of cylinders by type, empty or full
- Modular system allows for flexibility to suit individual or changing storage requirements
- Chain anchor plates allow all cylinder sizes to be individually restrained
- Gas cylinder storage area safety sign supplied
- Fast and easy assembly
- Can be safely secured to floor using masonry bolts
- Additional racking bays (GBSR8-AR) are simply bolted on
- Designed to relevant Australian standards including AS 4332
- Zinc finish for long life corrosion protection

Supplied flatpack for on-site assembly



Available in a range of sizes

### Specifications:

Inside Dimensions	900 (w) x 450 mm (d)
GBSR8 O/All Dimensions	1000 (w) x 500 (d) x 840 mm (h)
GBSR8 Unit Weight	35 kg
GBSR8-AR O/All Dimensions	950 (w) x 500 (d) x 840 mm (h)
GBSR8-AR Unit Weight	26 kg

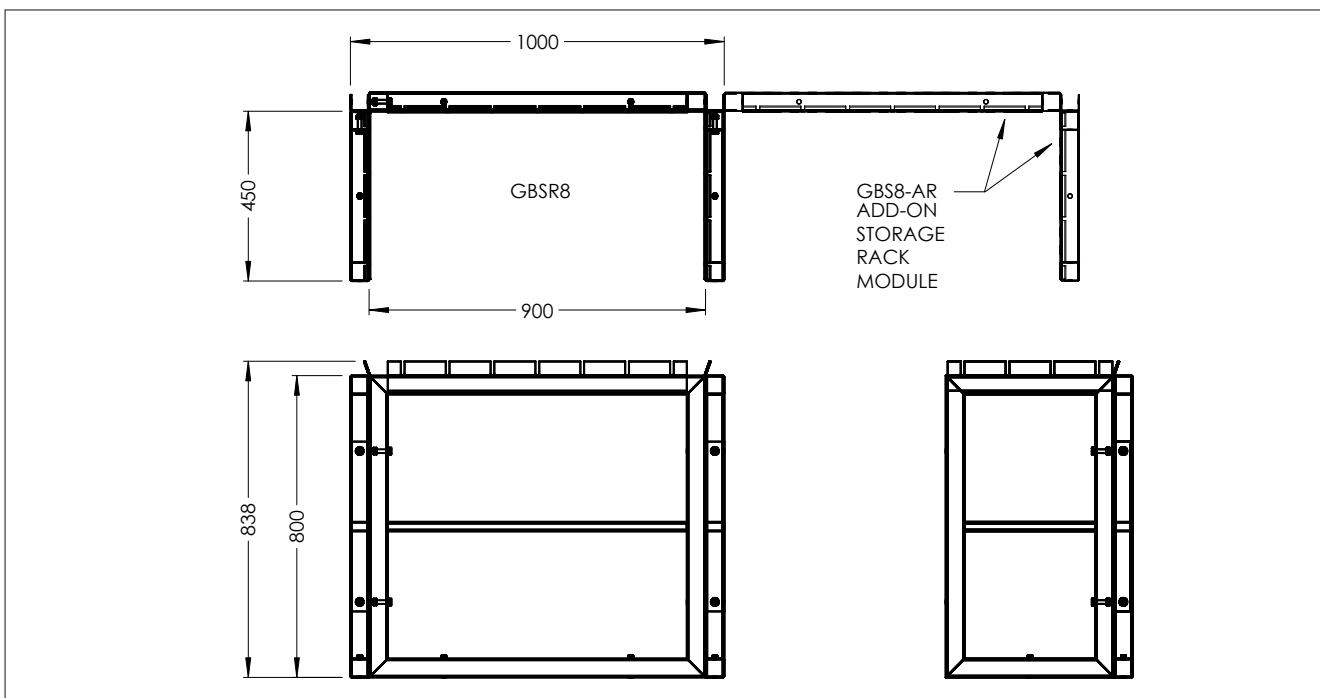

Australia Wide Sales & Service

sales@materialshandling.com.au | www.materialshandling.com.au | 1300 25 84 07

**MATERIALS**  
**Handling** PTY LTD *Working with ease.*