

GZUNDA BED MOVER SPECIFICATIONS

The Gzunda hospital bed mover is intelligently designed for moving patients safely. It is simple-to-use and is powerful enough for a person to move hospital beds weighing up to 500 kg, single-handedly. Whether you're moving patients between wards, or to and from the operating theatre, the Slimline Bed Mover keeps your medical staff safe from muscle and back strains.

It has easy-to-use controls, including key start, twist grip variable speed control, horn, and emergency stop button. As with all Electrodrive equipment, the Slimline Bed Mover comes with a comprehensive 12-month warranty, including parts and labour.



Typical applications

Suitable for moving hospital beds.

Features

Load capacity	Move up to 500 kg at 6° incline
Max. speed	Up to 5 km/hour
Speed mode	Three speed control with forward reverse and emergency stop.
Usability	<ul style="list-style-type: none"> • Compact and easy to manoeuvre in tight spaces • Intuitive controls with twist grip throttle and horn. • Requires 90 mm of under-bed clearance. • No driver's licence required. • Simple to use. • Quiet, smooth operation. • Zero emissions. • Non-marking tyres.
Hitching	<ul style="list-style-type: none"> • Push-button hitching—silent, fast and efficient. • A variety of hitches are available.
Dimensions (L/W/H)	1190/780/1126 mm
Battery	Two 12V 26Ah MK-gel batteries with 24 V smart charger.

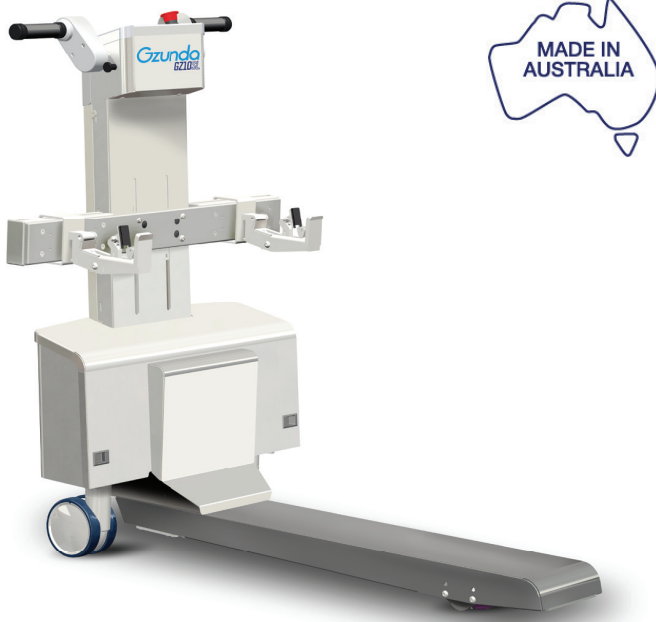

Gripper Hitch Shown. Hitches sold separately.

ORDER CODE

Gzunda MELGZN 500 kg – no hitch

MELGZN

Safety features

- Emergency stop button.
- Emergency back-off button.



MHT1810C Flex Hitch

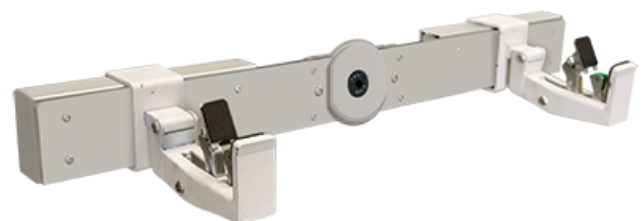

MH1701 Automatic Gripper Hitch

Australia Wide Sales & Service

sales@materialshandling.com.au | www.materialshandling.com.au | 1300 25 84 07

MATERIALS
Handling PTY LTD *Working with ease.*

The Bed Mover Range:

MELGZN Slimline The most popular bed mover in Australia. Suits most standard beds.



Load capacity	500 kg at 6° incline
Features	<ul style="list-style-type: none"> ▪ Compact and easy to manoeuvre in tight corridors. ▪ Requires 90 mm of clearance under the bed.
Voltage	24 V
Speed	Up to 5 km/h
Order Code	MELGZN

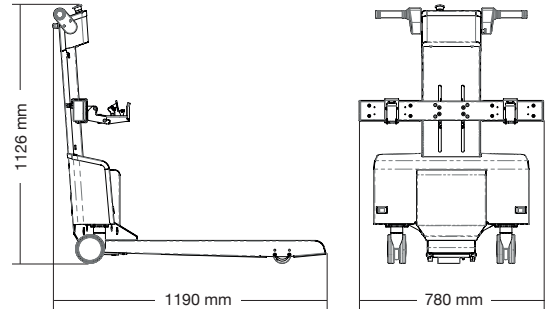

MELGZS Suits bulky beds with no ' under bed clearance'.



Load capacity	600 kg at 6° incline
Features	No under-bed clearance required.
Voltage	24 V
Speed	Up to 4 km/h
Order codes	MELGZS (for beds 800 mm wide)
	MELGZUS (for beds 900 mm wide)

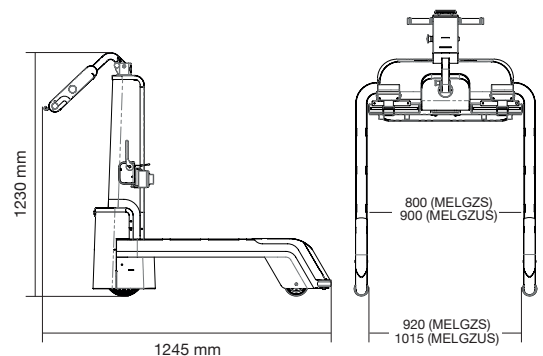

MP5WB Retractable A retrofittable solution for converting hospital beds into powered ones.



The MP5WB (hand control and drive wheel) fitted to a hospital bed.



Motorised retractable drive wheel (left) and hand control unit (right).

Load capacity	400 kg on flat ground
Features	<p>Sold as a complete system. The retrofittable kit includes:</p> <ul style="list-style-type: none"> ▪ Gzunda-style two-hand control unit ▪ Motorised retractable fifth wheel in carriage ▪ Slide-out battery carriage ▪ Batteries: 2 x 33 Ah gel ▪ Charger ▪ 1 year warranty
Voltage	24 V / 33 Ah
Speed	Up to 4.5 km/h
Order code	MP5WB

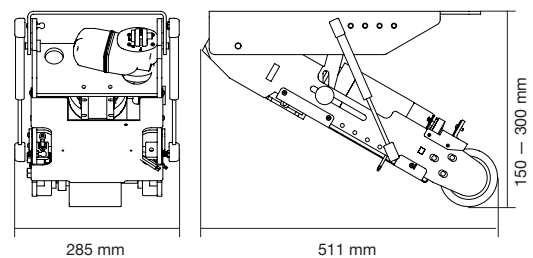

Ask about our fitting services.