

# FORKLIFT MOUNTED WHEELIE BIN TIPPER MNWBT2 SPECIFICATIONS

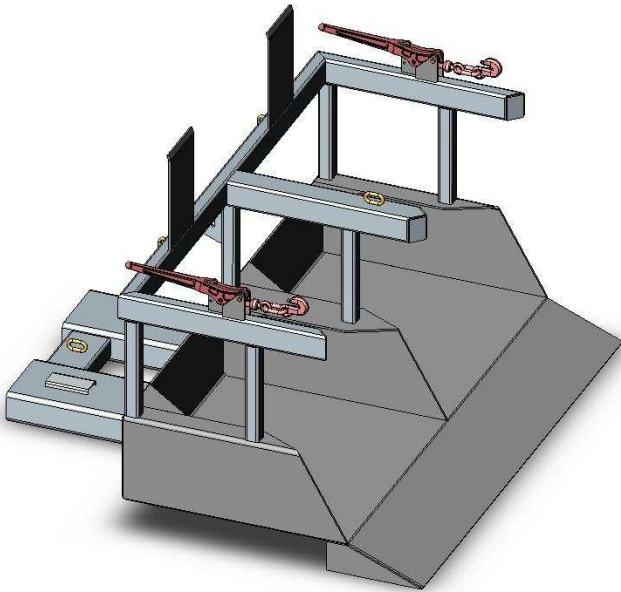

The type MNWBT2 Wheelie Bin Tipper has been designed for emptying 1 or 2 standard 240 litre plastic bins. The Bins are wheeled into the cradle and secured by the Safety Chains attached to the Backrests allowing the bins to be lifted/transported about the workplace and emptied. The tipping operation is simple and safe with the operator never having to leave his seat.

Standard finish on all Wheelie Bin Tipper is painted enamel.

## SPECIFICATIONS:

- Safe Working Load (SWL) 1000kg
- Load Centre 1200mm
- Unit Weight 150kg
- Pocket Size 165 x 65
- Pocket Centres 340
- Capable of 180° Rotation
- Horizontal C of G 720mm
- Vertical C of G 90mm

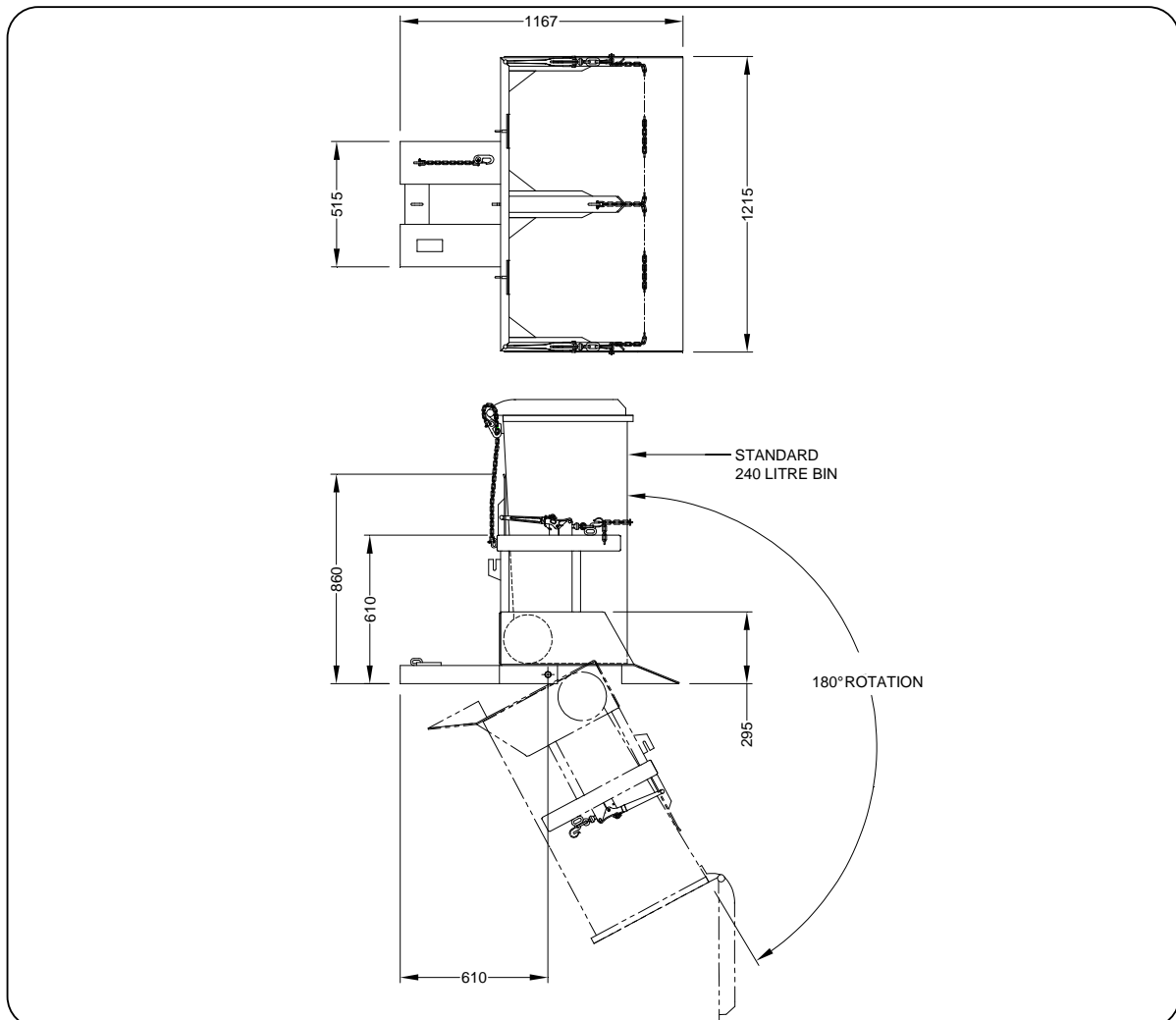

Australia Wide Sales & Service

sales@materialshandling.com.au | www.materialshandling.com.au | 1300 25 84 07

**MATERIALS**  
**Handling** PTY LTD *Working with ease.*