

MEGABIN ROTATOR BASE WMBRB SPECIFICATIONS

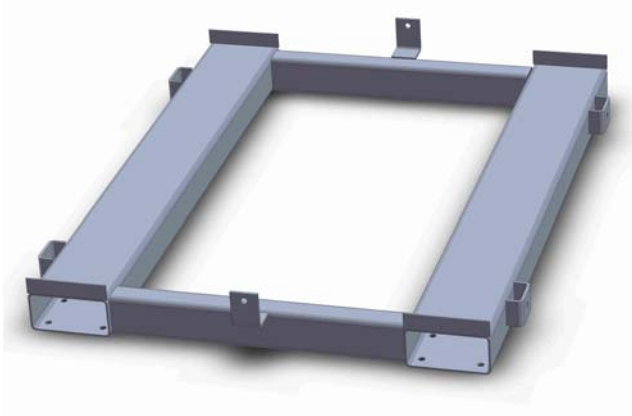

The type WMBRB Mega Bin Rotator Base is designed to bolt with a standard Mega Bin greatly increasing the functionality of this industry standard plastic bin. The WMBRB allows for rotation of the bin where a forklift is fitted with a 180 or 360 degree rotating attachment.

The WMBRB Base is securely bolted to the Mega bin in 6 positions, with all fasteners supplied.

The standard finish Zinc plated.

SPECIFICATIONS:

- Working Load Limit: 500 kg
- Unit Weight: 30 kg
- Pocket size: 140 x 68 mm
- Pocket Centres: 688 mm
- Load Centre: 535 mm
- HCG: 280 mm
- Wheels Optional

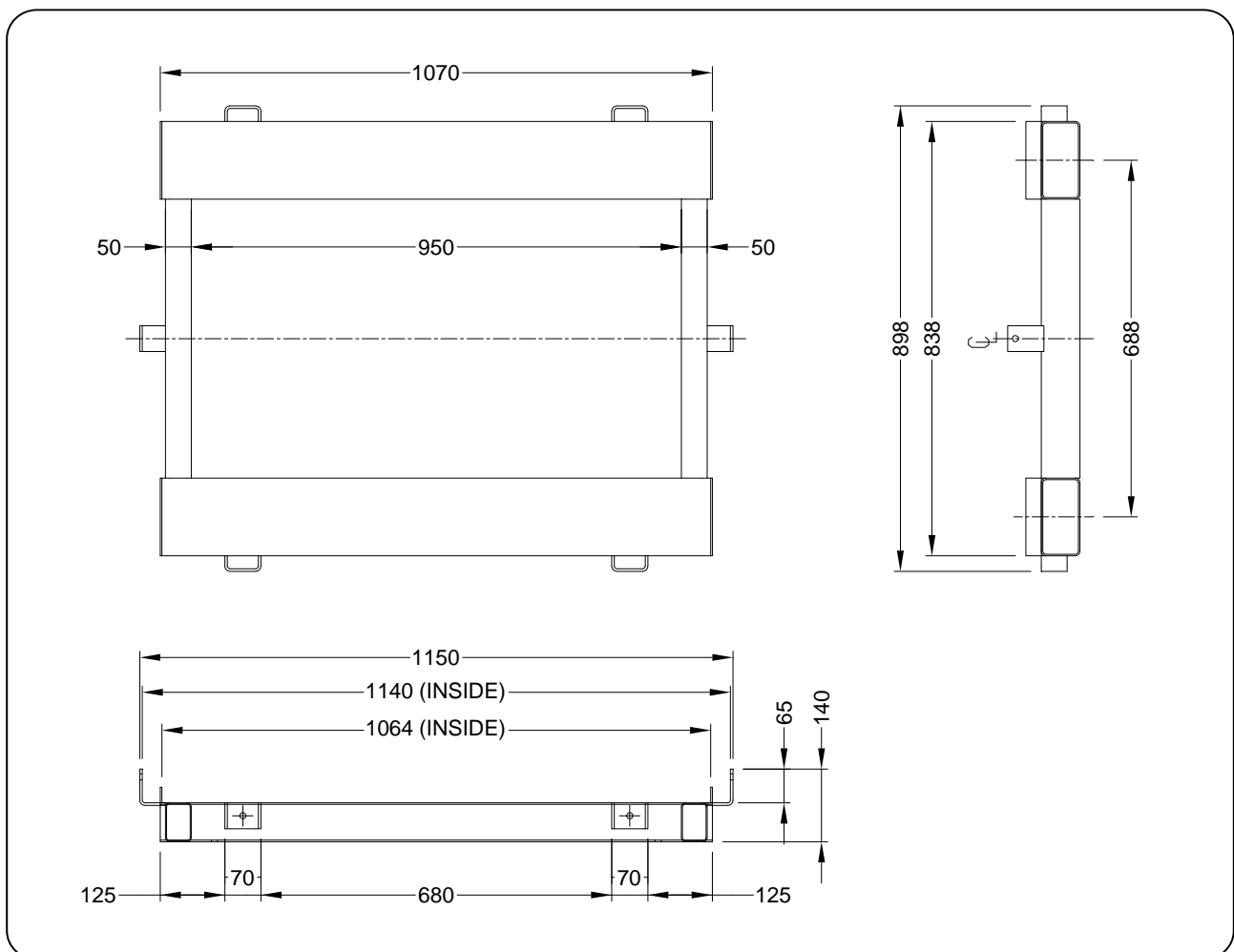

Australia Wide Sales & Service

sales@materialshandling.com.au | www.materialshandling.com.au | 1300 25 84 07

MATERIALS
Handling PTY LTD *Working with ease.*