

MATHAND MOBILE LIFT TROLLEYS SPECIFICATIONS

MatHand Mobile Lift Trolleys are incredibly versatile with an amazing feature that allows them to lift and move heavy loads. Our trolleys are convenient, easy to use and robust - designed to suit a range of applications.

'N' Series Trolleys:

- MN49 Lift: 900 mm - Table 500 x 400 mm
- MN412 Lift: 1200 mm - Table 500 x 400 mm
- MN612 Lift: 1200 mm - Table 600 x 600 mm
- MN615 Lift: 1460 mm - Table 600 x 600 mm

Lift Capacity: 150 kg
 Manual Winch Lift
 Wheels: 250 mm Pneumatic
 Optional: 200 mm Solid Rubber

'G' Series Trolley:

- MG412 Lift: 1200 mm - Table 500 x 400 mm

Lift Capacity: 150 Kg
 Manual Winch Lift
 Wheels: 200mm Solid x 75mm Swivel

Additional Information and Options:

Custom lift heights available

Available with:

- Gas Cylinder cradle
- Drum and Box rear support
- Restraint strap support
- Custom Table

Also available in Stainless steel

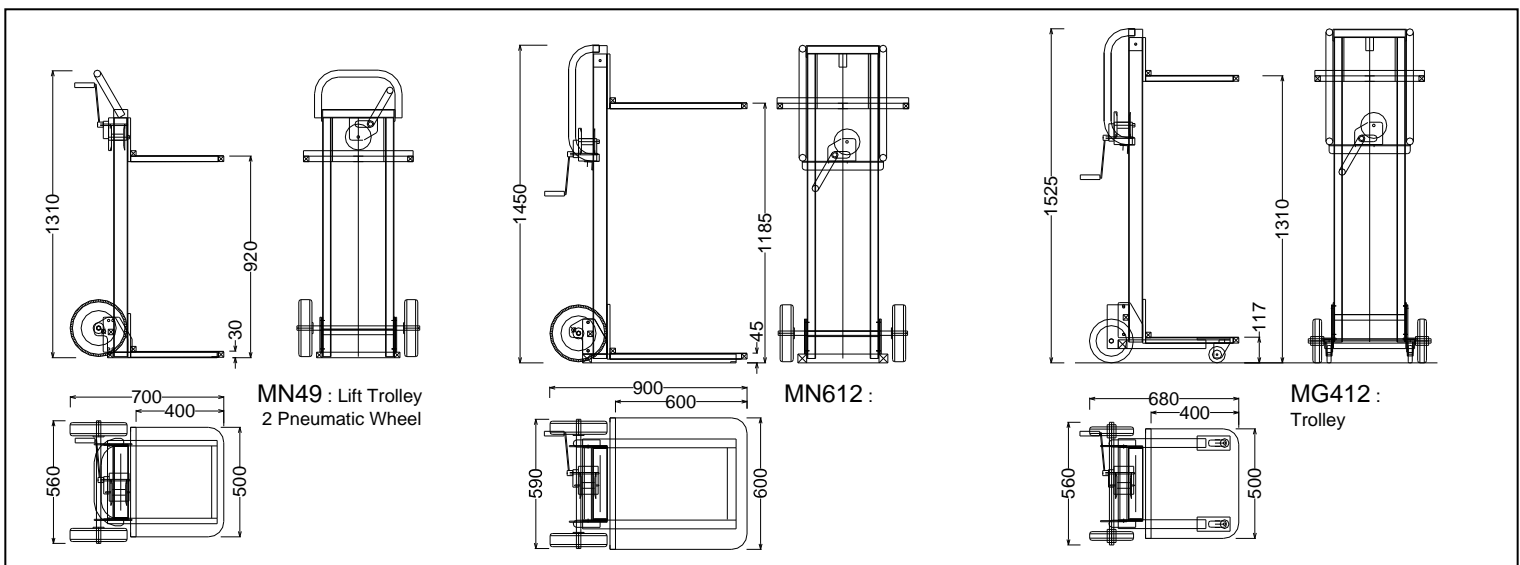

Australia Wide Sales & Service

sales@materialshandling.com.au | www.materialshandling.com.au | 1300 25 84 07

MATERIALS
Handling PTY LTD Working with ease™