

# SITE TOOL CABINET MBJ12 SPECIFICATIONS

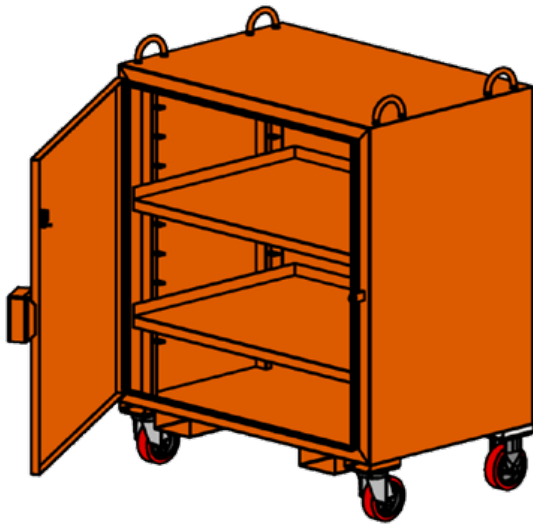

The MBJ12 Site Tool Cabinet is designed as a secure storage solution on work sites that can be transported by overhead crane and forklift. It also safely secures tools and equipment in a robust storage unit that features a heavy-duty and tough construction.

## FEATURES:

- Heavy duty construction
- Fitted with crane lugs and fork pockets for easy relocation
- 2 adjustable shelves allowing flexible storage options
- Dual locking mechanism door provides security against theft
- Weather and dust proof seal
- Designed & certified in accordance with Australian Standards
- Wheels fitted (removable)
- Enamel paint finish



Working Load Limit (WLL)	1000 kg
Opening Dimensions	1040 x 1040 mm
Overall Dimensions	1170 x 850 x 1450 mm
Unit Weight	180 kg
Fork Pocket Size	155 x 55 mm
Fork Pocket Centres	765 mm

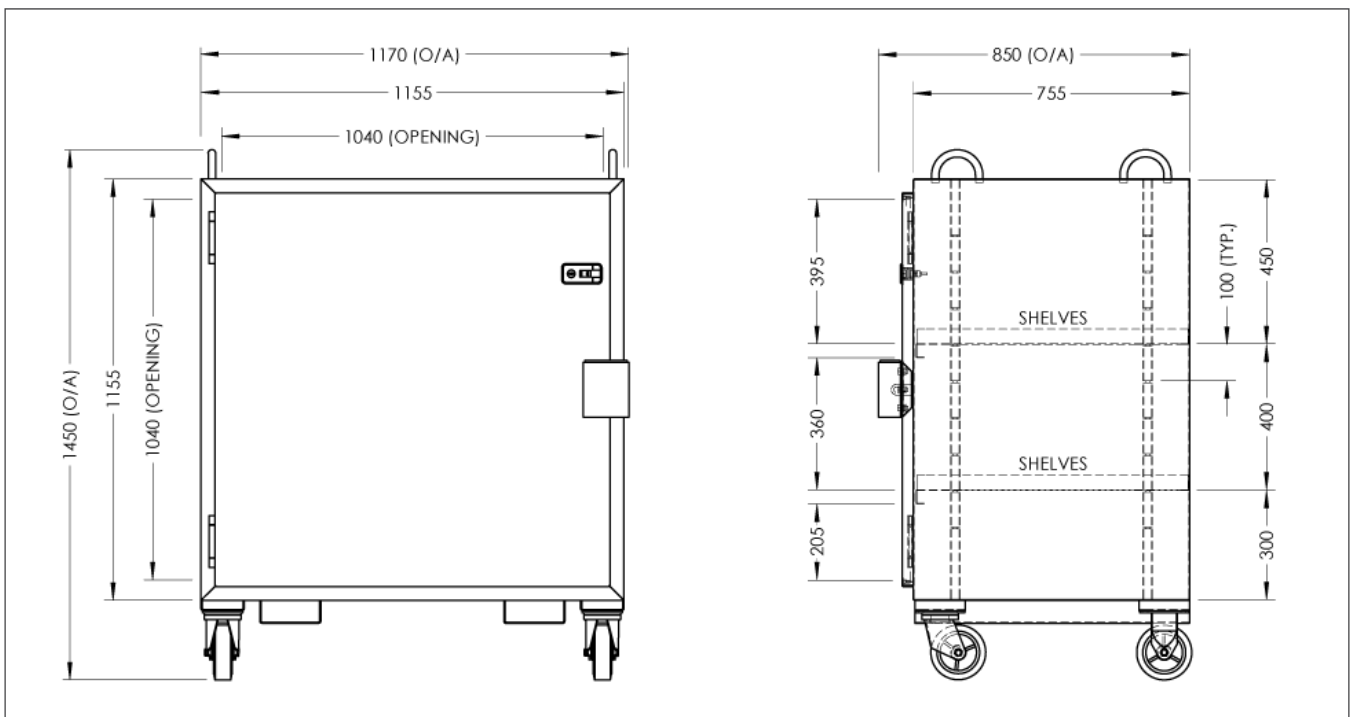

Australia Wide Sales & Service

sales@materialshandling.com.au | www.materialshandling.com.au | 1300 25 84 07

**MATERIALS**  
**Handling** PTY LTD Working with ease™