

e-drive Powered Trolley Kit

Please ask for more information

MATERIALS
Handling PTY LTD *Working with ease.*

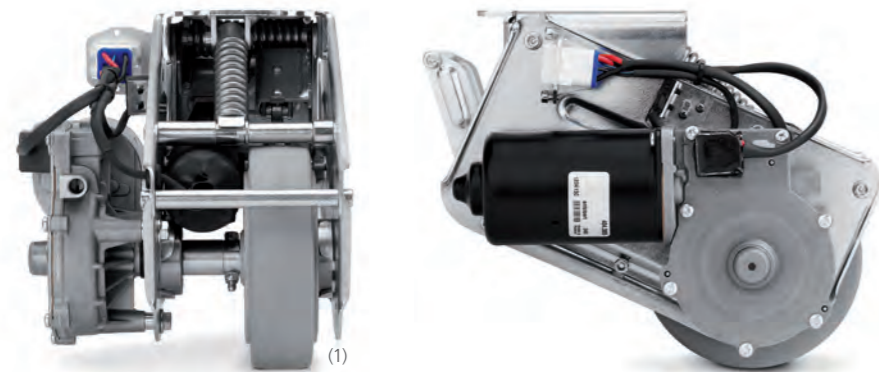

e-drive Powered Trolley Kit consists of:

- (1) e-drive Flex unit
- (2) Control unit
- (3) Handle
- (4) Mounting kit for the handle for tubes (in different diameters available) or plain surfaces
- (5) Battery module 4,5 Ah lead-gel with suitable battery charger (6).
 (e-drive Flex is also compatible for higher capacity.)

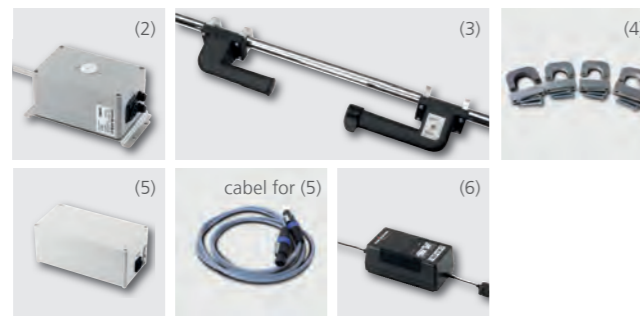

Application examples for e-drive Powered Trolley Kit:

Intralogistic

- Picking trolleys
- Parcel trolleys
- Special transport trolleys for e.g. carbody parts, tools, components

Catering

- Food distribution trolleys
- Induction trolleys

Hotel

- Hotel service trolleys
- Laundry trolleys
- Luggage trolleys

Hospital

- Food distribution trolleys
- Induction trolleys
- Surgery tables

Features

Operation category:	Start assistance
Wheel type:	UFF solid rubber, non-marking (replaceable), Ø 125 mm
Power supply:	24 V DC
Operating temperature:	5°C to 40°C
Storage temperature:	-20°C to 50°C
Max. total weight:	400 kg
Capacity of battery module:	4,5 Ah lead-gel (standard)
Operating distance:	Suitable for approx. 200 run-cycles
Updates firmware:	USB interface
Operating safety:	Certified DIN EN ISO 13849
Protection grade:	IPX4
Humidity:	90°C non-condensing
Fitting options of the handle:	Flexible handle fitting for tubes and plain surfaces
Material handle:	Solid synthetic material
Switch unit:	Certified DIN ISO 13849

The product complies to the following essential health and safety requirements specified as defined by the Machinery Directive 2006/42/EC. (Appendix 2, Part 1, Article B for uncomplete machines.)



Materials Handling Pty Ltd

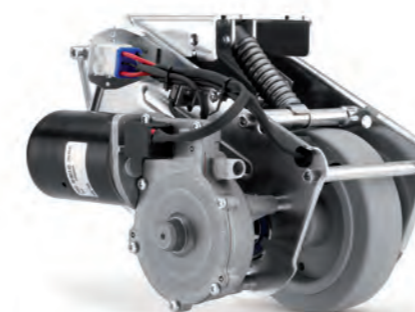

A moving solution e-drive Powered Trolley Kit

Australia Wide Sales & Service

sales@materialshandling.com.au | www.materialshandling.com.au | 1300 25 84 07

MATERIALS
Handling PTY LTD *Working with ease.*



MATERIALS
Handling PTY LTD *Working with ease.*

e-drive Powered Trolley Kit

Get heavy loads moving effortlessly with this efficient starting assistance

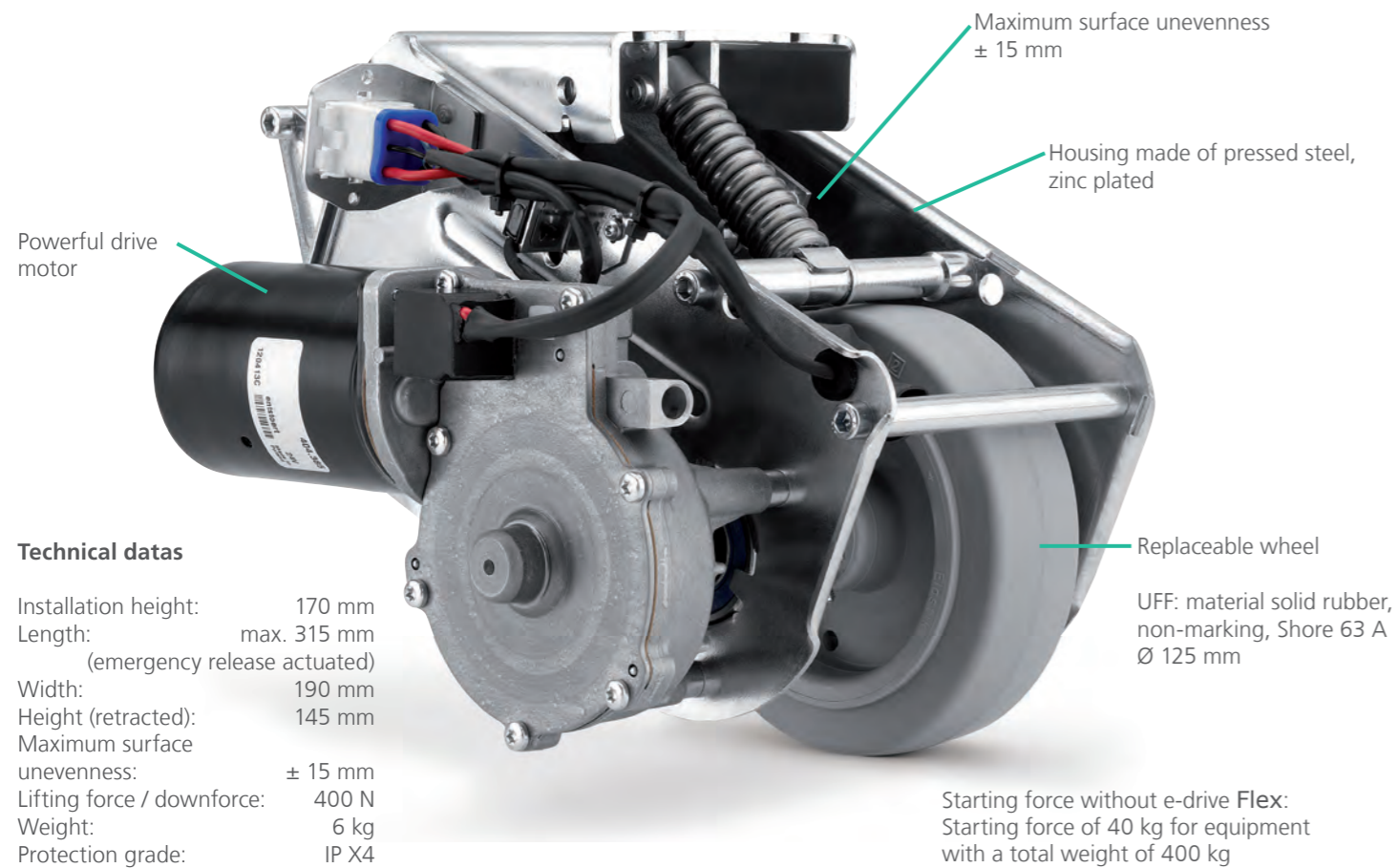

Technical datas

Installation height:	170 mm
Length:	max. 315 mm (emergency release actuated)
Width:	190 mm
Height (retracted):	145 mm
Maximum surface unevenness:	± 15 mm
Lifting force / downforce:	400 N
Weight:	6 kg
Protection grade:	IP X4

Create added value

- + Easy mobilising of heavy loads.
- + Increase manpower performance by saving effort.
- + Fast refinancing through reduced sick leave.
- + Easy plug & play installation, ideal for retrofitting.
- + Health prevention for staff: prevent neck, back, shoulder and wrist pain.
- + Improved tracking stability when mobilising heavy loads.
- + Infinite speed regulation (forward and reverse) through safety-tested operation.



Standby position guarantees free trolley flexibility.



Ergonomic handle design with system and battery charge LED indicators



Flexible installation (horizontal or vertical) for tube or plain surface mounting.